

NOZZLE SCHEDULE							REMARKS
ITEM	SIZE	RATING	TYPE	MATL.	PROJ IN	PROJ OUT	
A	3"	N.P.T	W.F	C.S	STD.	STD.	PRIMARY EMERGENCY VENT OPENING
B	3"	N.P.T	W.F	C.S	STD.	STD.	SECONDARY EMERGENCY VENT OPENING
C	2"	N.P.T	W.F	C.S	STD.	STD.	

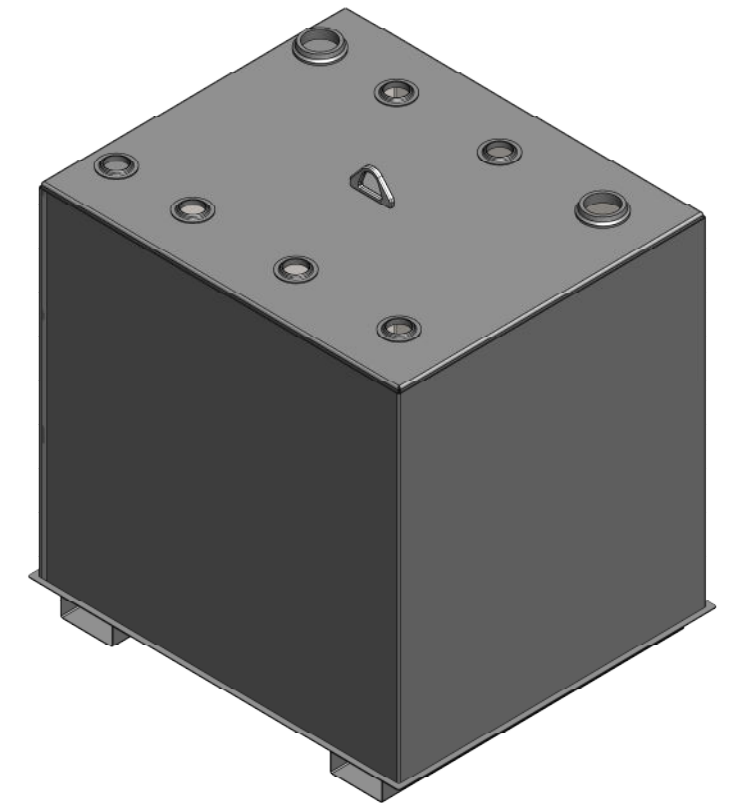
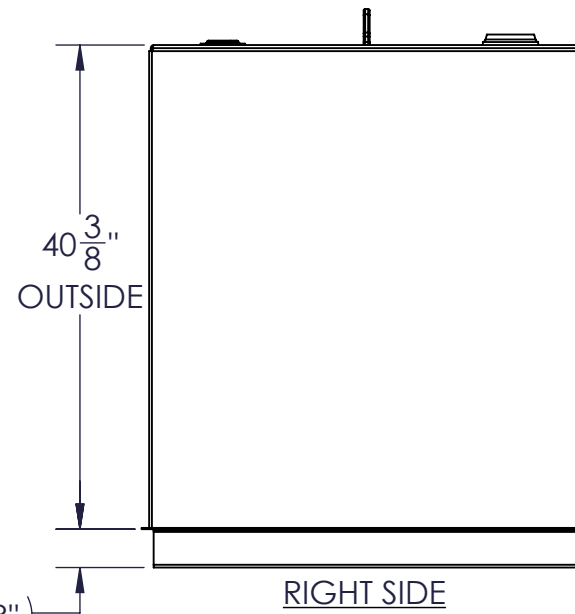
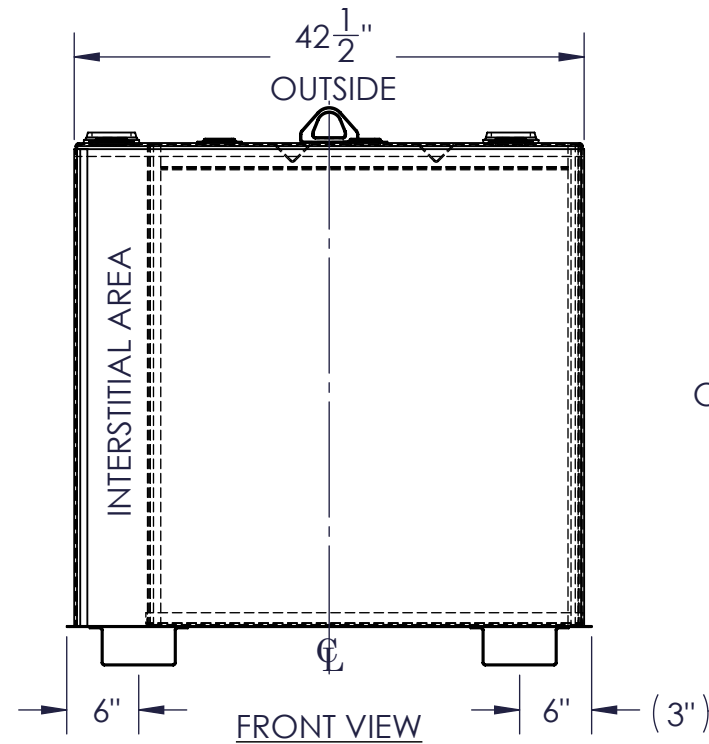
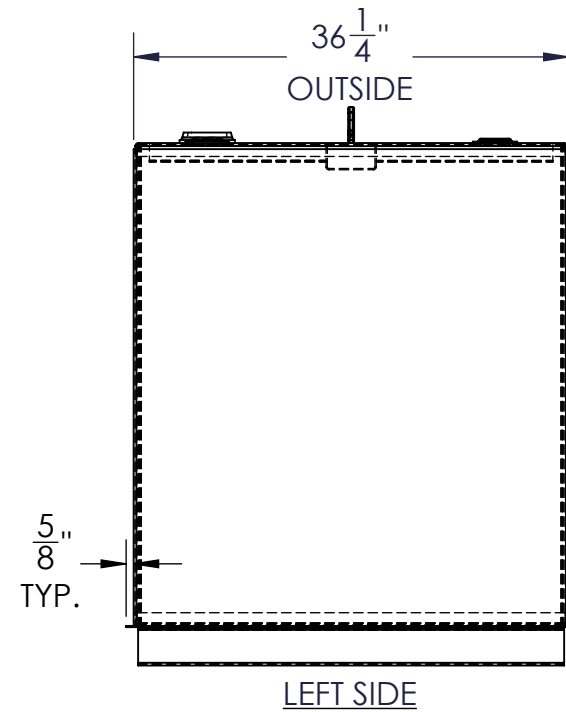

NOTES:

- A. MATERIAL: H.R. CARBON STEEL.
- B. DESIGN & OPERATING PRESSURE: ATMOSPHERIC.
- C. DESIGN & OPERATING TEMPERATURE: AMBIENT.
- D. TANK TO BE BUILT & LABELED PER U.L. SPEC. #142.
- E. TANK TO BEAR MANUFACTURERS & U.L. LABELS ONLY.
- F. TANK TO BE AIR TESTED WITH WATER & SOAP SUDS SOLUTION.
- G. INTERIOR: REMOVE WELD SLAG (SHIP CLEAN & DRY).
- H. EXTERIOR: GRAY PRIMER INCLUDED; SEE SALES ORDER FOR TOP COAT.
- I. ALL FITTINGS TO BE PROTECTED FOR SHIPMENT.
- J. CUSTOMER HAS THE RESPONSIBILITY TO VERIFY ALL DIMENSIONS.

APPROVAL FOR CONSTRUCTION
SCHEDULE A - MASTER TERMS &
CONDITION OF SALE*

- APPROVED AS DRAWN.
 - APPROVED WITH NOTED CHANGES,
CONSTRUCTION WILL BE SCHEDULED
WHEN SIGNED DRAWING AND
CONFIRMED ORDER ARE RECEIVED.
- SIGNATURE: _____
DATE: _____

SALES ORDER: -



PO Box 700338
Wabasso, FL 32970
863-261-8388
info@oneclarion.com

WEIGHT (LBS): **559**

All units inches
unless stated
otherwise

DESCRIPTION:

220 GALLON RECTANGULAR UL 142 DOUBLE WALL TANK

CUSTOMER:

P.O.#

DATE:
5/4/2023

SCALE:

DWG.#
FTDBSW-0220

DRAWN BY: **AJC**
CHKD BY: **-**