

NOZZLE SCHEDULE							REMARKS
ITEM	SIZE	RATING	TYPE	MATL.	PROJ IN	PROJ OUT	
A	4"	N.P.T	W.F	C.S	STD.	STD.	PRIMARY EMERGENCY VENT OPENING
B	4"	N.P.T	W.F	C.S	STD.	STD.	SECONDARY EMERGENCY VENT OPENING
C	2"	N.P.T	W.F	C.S	STD.	STD.	

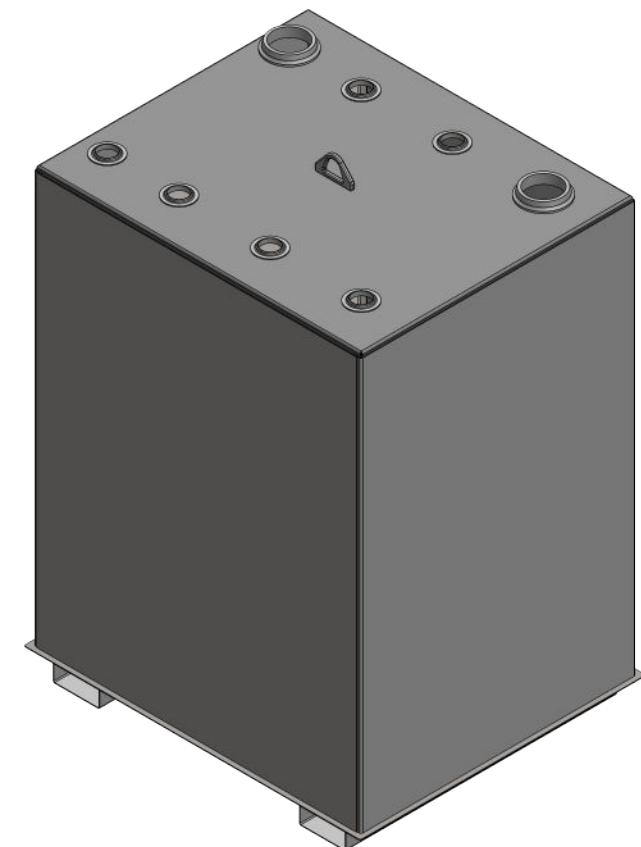
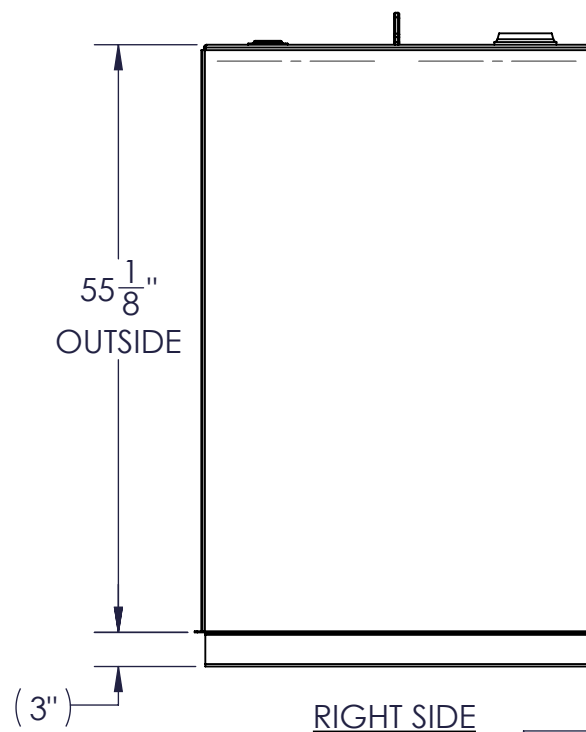
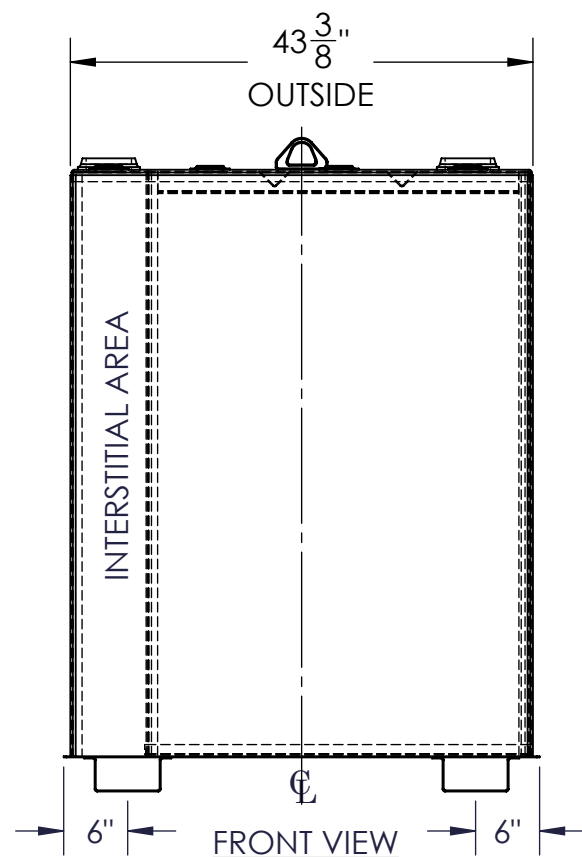
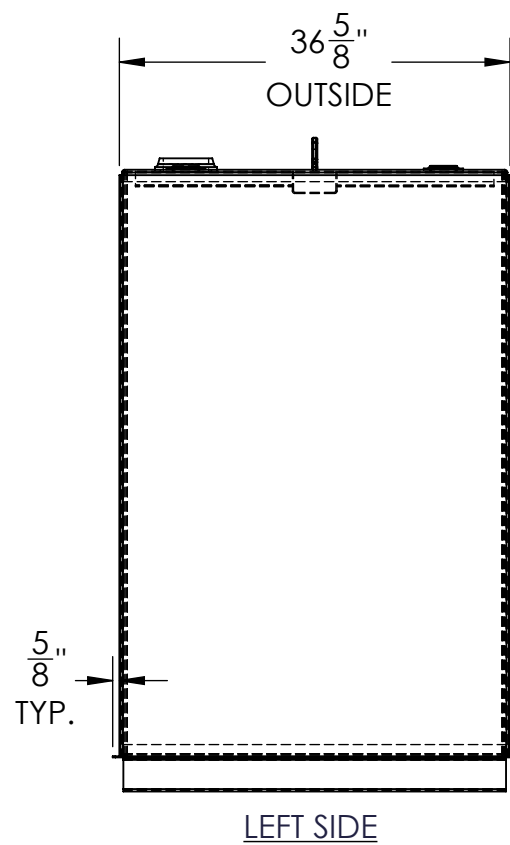

**NOTES:**

- A. MATERIAL: H.R. CARBON STEEL
- B. DESIGN & OPERATING PRESSURE: ATMOSPHERIC.
- C. DESIGN & OPERATING TEMPERATURE: AMBIENT.
- D. TANK TO BE BUILT & LABELED PER U.L. SPEC. #142.
- E. TANK TO BEAR MANUFACTURERS & U.L. LABELS ONLY.
- F. TANK TO BE AIR TESTED WITH WATER & SOAP SUDS SOLUTION.
- G. INTERIOR: REMOVE WELD SLAG (SHIP CLEAN & DRY).
- H. EXTERIOR: GRAY PRIMER INCLUDED; SEE SALES ORDER FOR TOP COAT.
- I. ALL FITTINGS TO BE PROTECTED FOR SHIPMENT.
- J. CUSTOMER HAS THE RESPONSIBILITY TO VERIFY ALL DIMENSIONS.

APPROVAL FOR CONSTRUCTION  
SCHEDULE A - MASTER TERMS &  
CONDITION OF SALE\*

- APPROVED AS DRAWN.
  - APPROVED WITH NOTED CHANGES,  
CONSTRUCTION WILL BE SCHEDULED  
WHEN SIGNED DRAWING AND  
CONFIRMED ORDER ARE RECEIVED.
- SIGNATURE: \_\_\_\_\_  
DATE: \_\_\_\_\_

**SALES ORDER: -**

www.oneclarion.com			PO Box 700338 Wabasso, FL 32970 863-261-8388 info@oneclarion.com	WEIGHT (LBS): <b>702</b>
DESCRIPTION: 300 GALLON RECTANGULAR UL 142 DOUBLE WALL TANK				
CUSTOMER:			P.O.#	
DATE: 3/7/2023	SCALE:	DWG.# FTDBSW-0300	DRAWN BY: <b>AJC</b> CHKD BY: _____	