

| NOZZLE SCHEDULE | | | | | | | |
|-----------------|------|--------|--------|-------|----------|-----------|----------------------------------|
| ITEM | SIZE | RATING | TYPE | MATL. | PROJ. IN | PROJ. OUT | REMARKS |
| A | 6" | N.P.T. | H.CPL. | C.S. | STD. | STD. | PRIMARY EMERGENCY VENT OPENING |
| B | 6" | N.P.T. | H.CPL. | C.S. | STD. | STD. | SECONDARY EMERGENCY VENT OPENING |
| C | 2" | N.P.T. | W.F. | C.S. | STD. | STD. | |

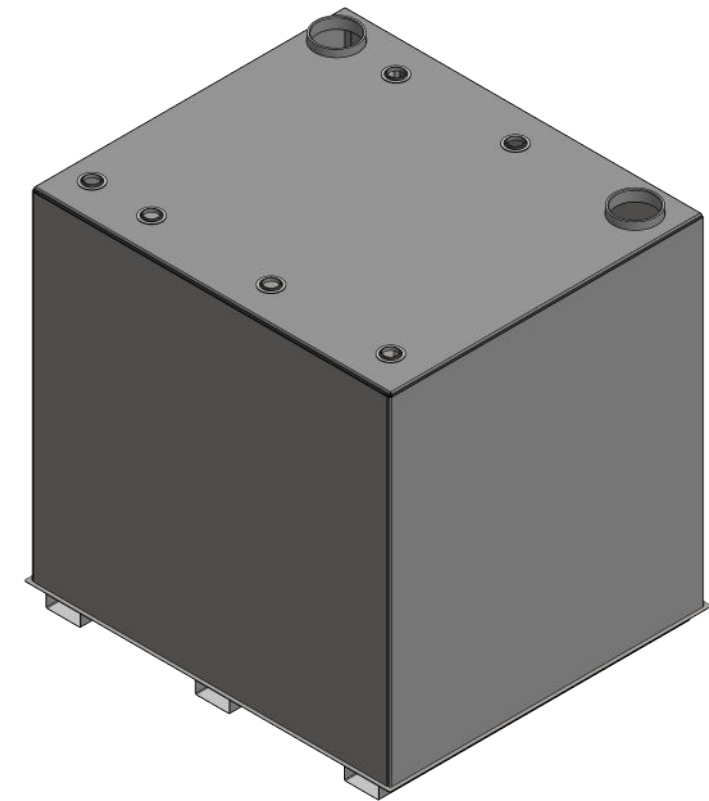
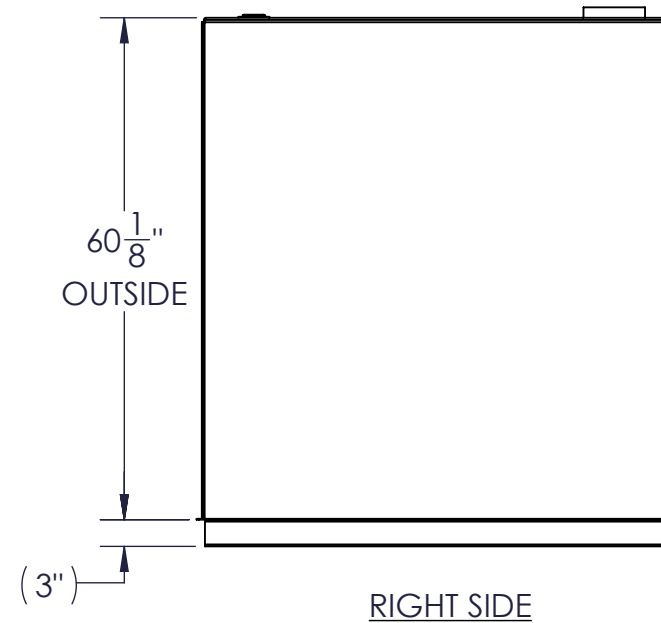
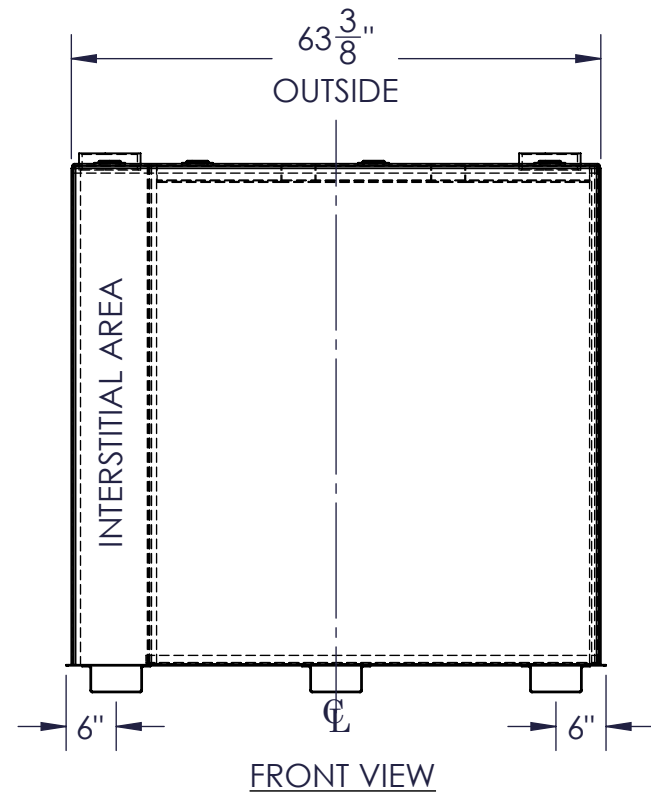
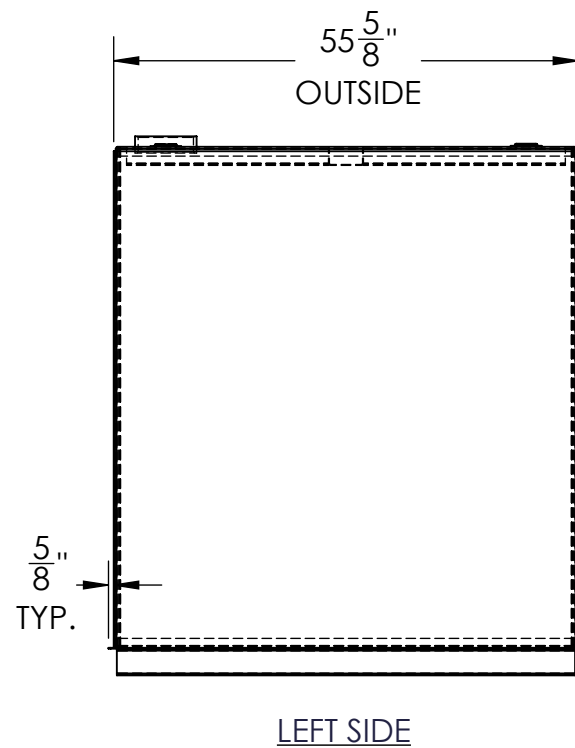

NOTES:

- A. MATERIAL: H.R. CARBON STEEL
- B. DESIGN & OPERATING PRESSURE: ATMOSPHERIC.
- C. DESIGN & OPERATING TEMPERATURE: AMBIENT.
- D. TANK TO BE BUILT & LABELED PER U.L. SPEC. # 142.
- E. TANK TO BEAR MANUFACTURERS & U.L. LABELS ONLY.
- F. TANK TO BE AIR TESTED WITH WATER & SOAP SUDS SOLUTION.
- G. INTERIOR: REMOVE WELD SLAG (SHIP CLEAN & DRY).
- H. EXTERIOR: GRAY PRIMER INCLUDED; SEE SALES ORDER FOR TOP COAT.
- I. ALL FITTINGS TO BE PROTECTED FOR SHIPMENT.
- J. CUSTOMER HAS THE RESPONSIBILITY TO VERIFY ALL DIMENSIONS.

APPROVAL FOR CONSTRUCTION
SCHEDULE A - MASTER TERMS &
CONDITION OF SALE*

- APPROVED AS DRAWN.
 - APPROVED WITH NOTED CHANGES,
CONSTRUCTION WILL BE SCHEDULED
WHEN SIGNED DRAWING AND
CONFIRMED ORDER ARE RECEIVED.
- SIGNATURE: _____
DATE: _____

SALES ORDER: -



PO Box 700338
Wabasso, FL 32970
863-261-8388
info@oneclarion.com

WEIGHT (LBS): 1398

All units inches
unless stated
otherwise

DESCRIPTION:

750 GALLON RECTANGULAR UL 142 DOUBLE WALL TANK

CUSTOMER:

P.O.#

DATE:
3/7/2023

SCALE:

DWG.#
FTDBSW-0750

DRAWN BY: AJC
CHKD BY: -