

NOZZLE SCHEDULE							
ITEM	SIZE	RATING	TYPE	MATL	PROJ IN	PROJ OUT	REMARKS
A	4"	N.P.T.	W.F.	C.S.	STD.	STD.	EMERGENCY VENT OPENING
B	2"	N.P.T.	W.F.	C.S.	STD.	STD.	
C	3/4"	N.P.T.	W.F.	C.S.	STD.	STD.	DRAIN

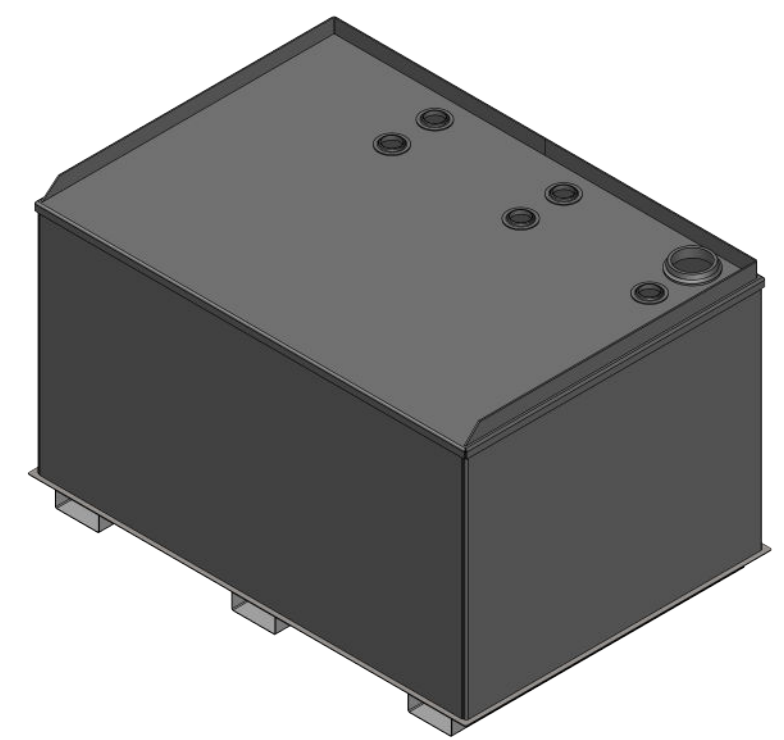
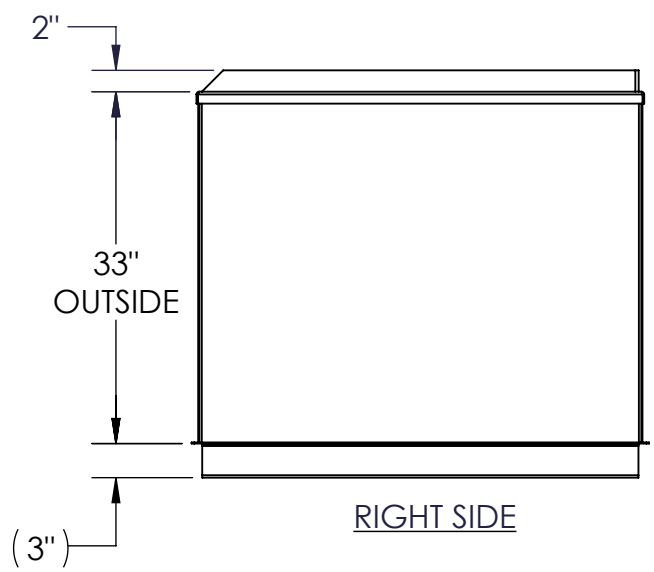
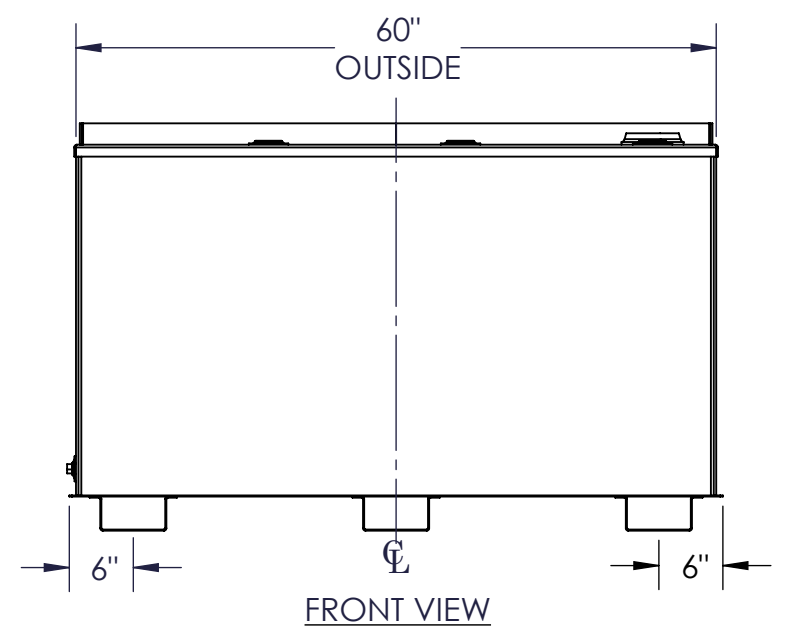
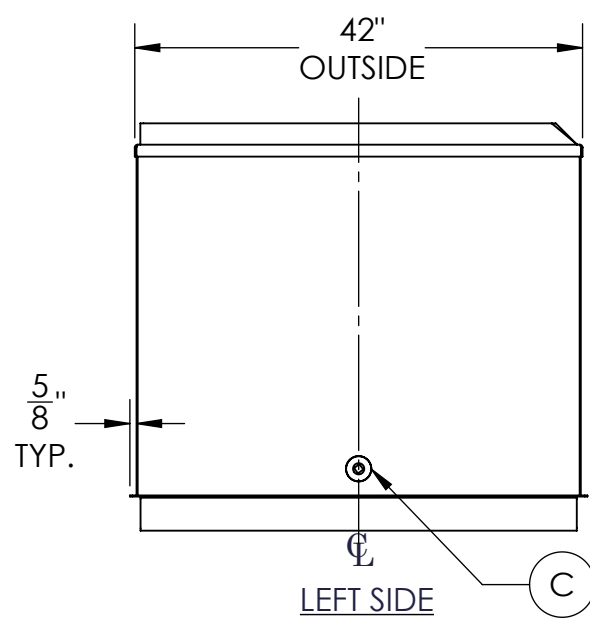

- NOTES:
- A. MATERIAL: H.R. CARBON STEEL
 - B. DESIGN & OPERATING PRESSURE: ATMOSPHERIC.
 - C. DESIGN & OPERATING TEMPERATURE: AMBIENT.
 - D. TANK TO BE BUILT & LABELED PER U.L. SPEC. #142.
 - E. TANK TO BEAR MANUFACTURERS & U.L. LABELS ONLY.
 - F. TANK TO BE AIR TESTED WITH WATER & SOAP SUDS SOLUTION.
 - G. INTERIOR: REMOVE WELD SLAG (SHIP CLEAN & DRY).
 - H. EXTERIOR: GRAY PRIMER INCLUDED; SEE SALES ORDER FOR TOP COAT.
 - I. ALL FITTINGS TO BE PROTECTED FOR SHIPMENT.
 - J. CUSTOMER HAS THE RESPONSIBILITY TO VERIFY ALL DIMENSIONS.

APPROVAL FOR CONSTRUCTION
SCHEDULE A - MASTER TERMS &
CONDITION OF SALE*

APPROVED AS DRAWN.

APPROVED WITH NOTED CHANGES,
CONSTRUCTION WILL BE SCHEDULED
WHEN SIGNED DRAWING AND
CONFIRMED ORDER ARE RECEIVED.

SIGNATURE: _____

DATE: _____

SALES ORDER: -		WEIGHT (LBS): 474
		PO Box 700338 Wabasso, FL 32970 863-261-8388 info@oneclarion.com
www.oneclarion.com		
DESCRIPTION:		
350 GALLON RECTANGULAR UL 142 SINGLE WALL BENCHTOP TANK		
CUSTOMER:		P.O.#
DATE: 3/7/2023	SCALE:	DWG.# FTSBSB-0350
DRAWN BY: AJC		CHKD BY: -