

NOZZLE SCHEDULE							
ITEM	SIZE	RATING	TYPE	MATL	PROJ IN	PROJ OUT	REMARKS
A	6"	N.P.T.	H.CPL.	C.S.	STD.	STD.	EMERGENCY VENT OPENING
B	2"	N.P.T.	W.F.	C.S.	STD.	STD.	
C	3/4"	N.P.T.	W.F.	C.S.	STD.	STD.	DRAIN

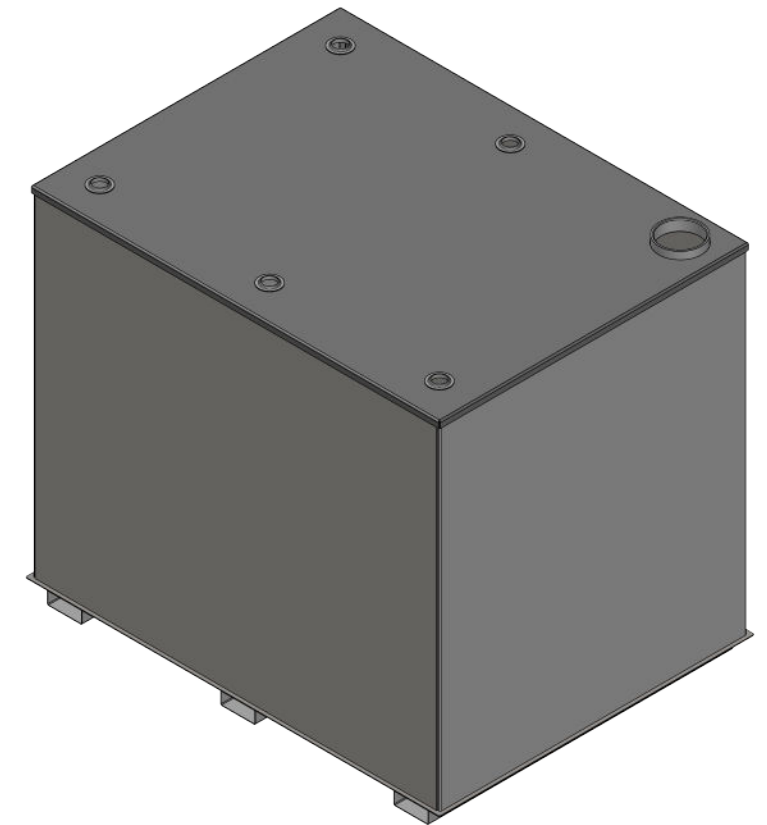
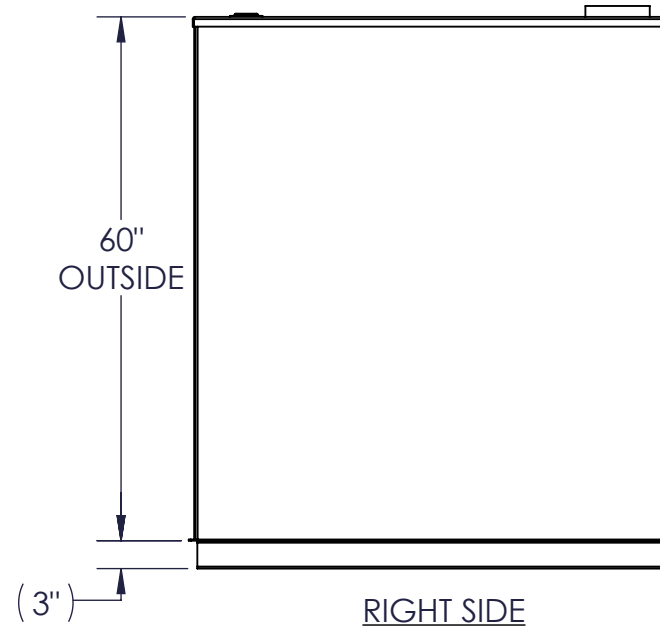
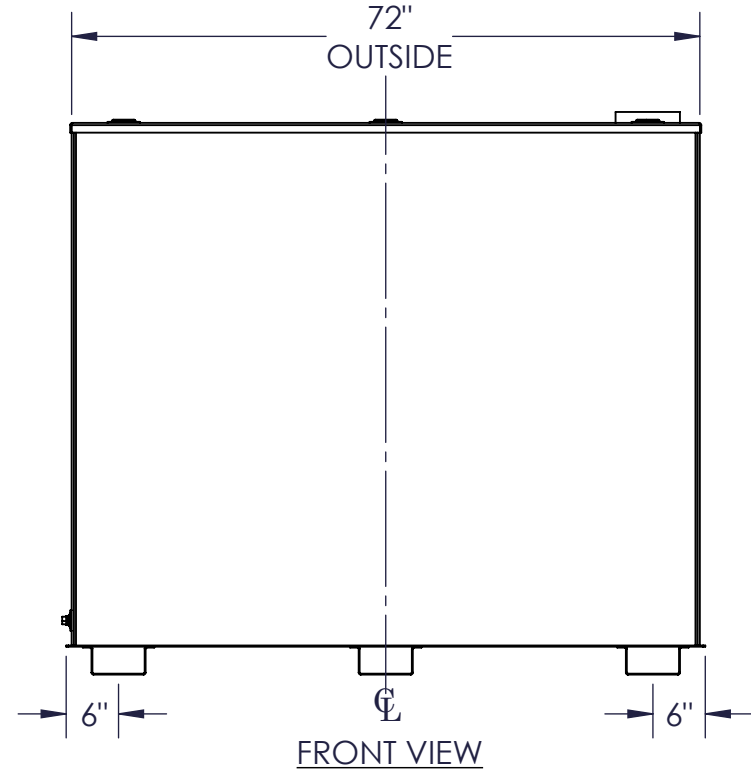
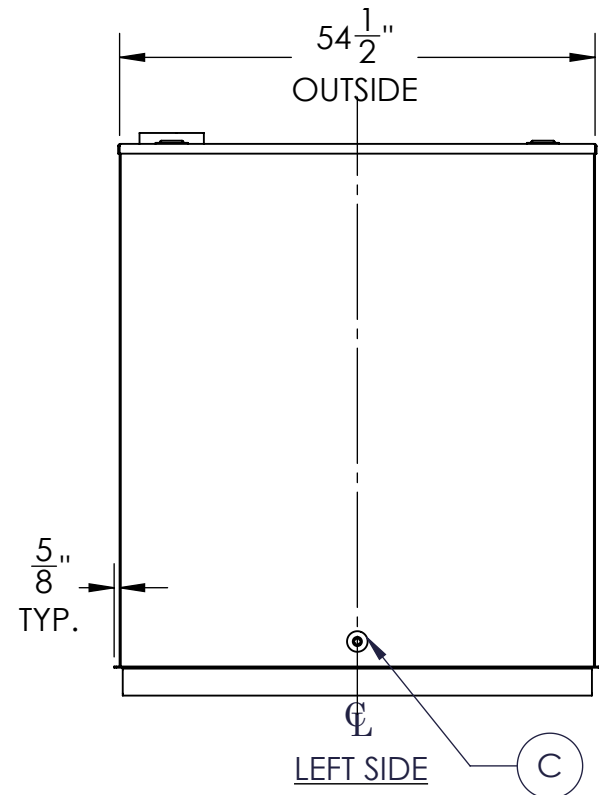

- NOTES:
- A. MATERIAL: H.R. CARBON STEEL
 - B. DESIGN & OPERATING PRESSURE: ATMOSPHERIC.
 - C. DESIGN & OPERATING TEMPERATURE: AMBIENT.
 - D. TANK TO BE BUILT & LABELED PER U.L. SPEC. #142.
 - E. TANK TO BEAR MANUFACTURERS & U.L. LABELS ONLY.
 - F. TANK TO BE AIR TESTED WITH WATER & SOAP SUDS SOLUTION.
 - G. INTERIOR: REMOVE WELD SLAG (SHIP CLEAN & DRY).
 - H. EXTERIOR: GRAY PRIMER INCLUDED; SEE SALES ORDER FOR TOP COAT.
 - I. ALL FITTINGS TO BE PROTECTED FOR SHIPMENT.
 - J. CUSTOMER HAS THE RESPONSIBILITY TO VERIFY ALL DIMENSIONS.

APPROVAL FOR CONSTRUCTION
SCHEDULE A - MASTER TERMS &
CONDITION OF SALE*

APPROVED AS DRAWN.

APPROVED WITH NOTED CHANGES,
CONSTRUCTION WILL BE SCHEDULED
WHEN SIGNED DRAWING AND
CONFIRMED ORDER ARE RECEIVED.

SIGNATURE: _____

DATE: _____

SALES ORDER: -

WEIGHT (LBS): **999**

ONE CLARION PO Box 700338
Wabasso, FL 32970
863-261-8388
www.oneclarion.com info@oneclarion.com

DESCRIPTION:
1000 GALLON RECTANGULAR UL 142 SINGLE WALL TANK

CUSTOMER: _____ P.O.# _____

DATE: 2/8/2023 SCALE: _____ DWG.# FTSSBW-1000 DRAWN BY: AJC
CHKD BY: _____

All units inches unless stated otherwise