



Ultra-Modular IBC Spill Pallet[®]

Assembly Instructions



Step 1: Place the (1) Pallets and /or (2) Expansion Tanks in the desired configuration

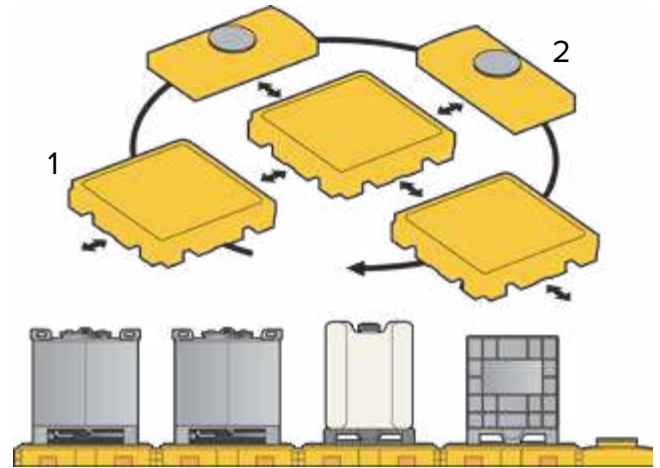

Step 2: Locate the two drill points on each mating sidewall of the (1) Pallet and/or (2) Expansion Tank. Note: the drill points are dimples in the sidewall that are located approximately 2 1/2" from the bottom of the (1) Pallet or (2) Expansion Tank and are 18" apart.

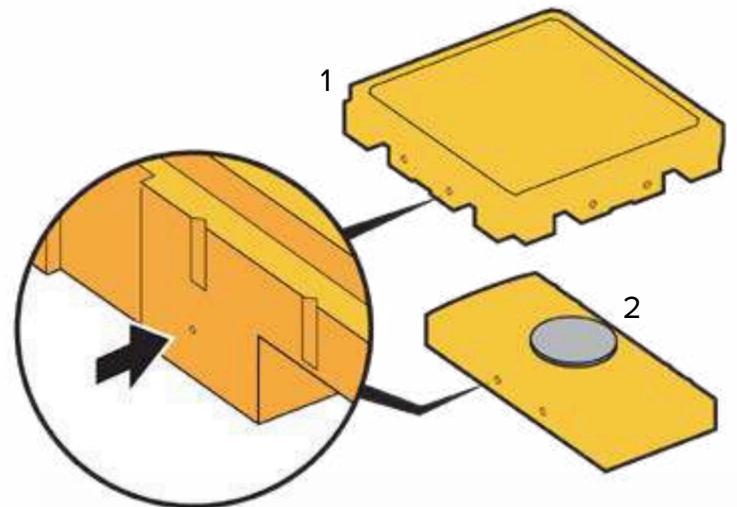

Step 3: Using the 2 3/8" hole saw, carefully place the drill bit of the hole saw in the center of the drill point and cut a hole through the sidewall.

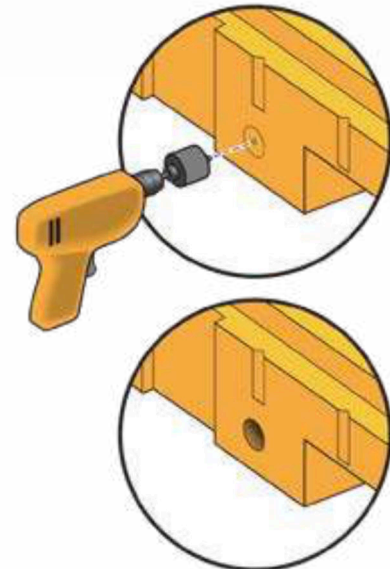

NOTE: WRENCH AND HOLE SAW KIT MUST BE PURCHASE SEPARATELY; PORTABLE DRILL AND (2) 3/8" DRIVE RACHETS NOT PROVIDED.

Ultra-Modular IBC Spill Pallet®

Assembly Instructions

Step 4: Repeat Step 3 for the remaining drill points in the sidewalls. (Requires two holes each sidewall)

Step 5: Repeat Steps 2, 3 and 4 for all mating sidewalls. CAUTION: only cut holes into the sidewalls that are intended to have a (3) bulk head fitting.

Step 6: Remove the grates from the (1) Pallet or open the lid of the (2) Expansion Tank to access the backside of hole. From the inside, insert a 1 ¼" (3A) bulk head fitting through the hole. Place two (3B) gaskets onto the inserted (3A) bulk head fitting before passing the (3A) bulk head fitting through the hole in the mating sidewall. Note: The (3B) gaskets should be between the mating sidewalls.

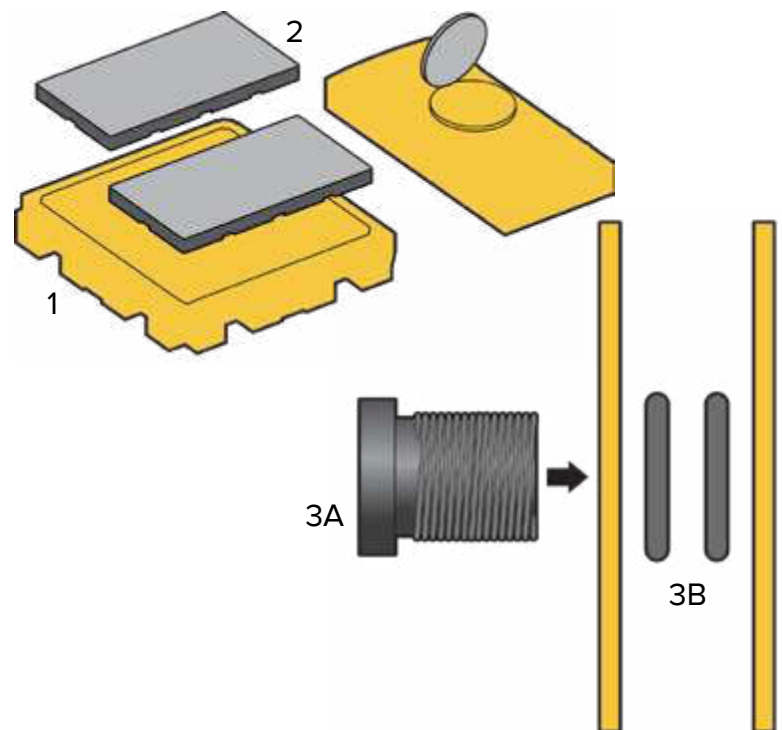

Step 7: Start a (3C) hex nut onto the (3A) bulk head fitting. Do not tighten. Note: These are left handed threads. Side of the (3C) hex nut with the word “tighten” and a directional arrow should be facing away from the (3A) bulk head fitting when attaching the (3C) hex nut to the (3A) bulk head fitting.

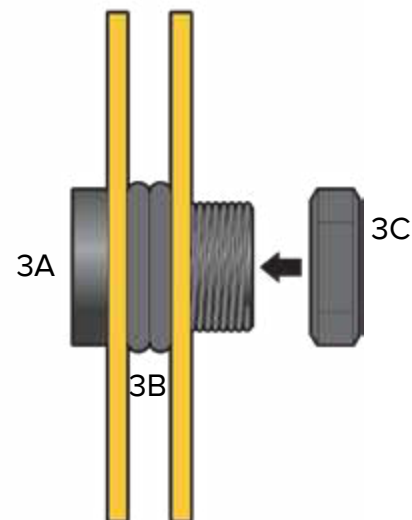

Ultra-Modular IBC Spill Pallet®

Assembly Instructions

Step 8: Repeat Steps 6 and 7 for the remaining mating holes in the sidewalls.

Step 9: Tighten the (3A) bulk head fittings using two 3/8" drive ratchets (not provided) along with the (4C) hex socket wrench and the (4A) lug spanner wrench. Note: (4A) lug spanner wrench is designed to fit over the lugs on the round side of the (3A) bulk head fitting. Tighten the (3A) bulk head fitting until the mating sidewalls are pulled together and the (3B) gaskets are slightly compressed.

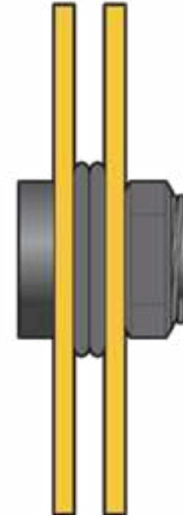

Step 10: Repeat steps 6 through 9 for the remaining sidewalls that were cut with the (4B) hole saw.

NOTE: MAKE SURE ALL
PLUG ASSEMBLIES ARE
TIGHT BEFORE PUTTING THIS PRODUCT IN USE

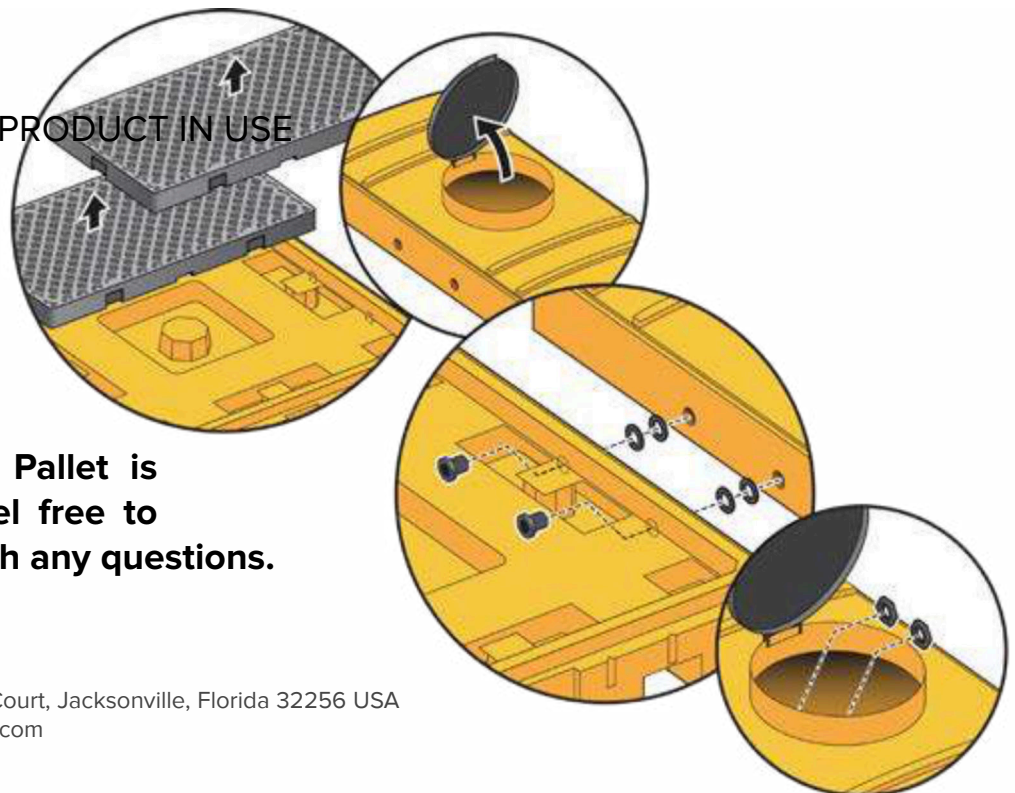

Your Ultra-Modular IBC Spill Pallet is now ready to use. Please feel free to contact us at 904-292-1611 with any questions.

UltraTech International, Inc. · 11542 Davis Creek Court, Jacksonville, Florida 32256 USA
(800) 353-1611 · 1-904-292-1611 · spillcontainment.com

Ultra-Modular IBC Spill Pallet®

Assembly Instructions

| Item | Part # | Description | 2-Tank Model | 3-Tank Model | 4-Tank Model | 5-Tank Model | Quantity |
|------|--------|---------------------------------|--------------|--------------|--------------|--------------|----------|
| 1 | 9630 | Yellow Spill Pallet | 2 | 3 | 4 | 5 | |
| 2 | 1124 | Yellow 66G. Expansion Tank | 2 | 2 | 1 | 0 | |
| 3 | 1117 | 1.25" Bulkhead Fitting Assembly | 3 | 4 | 4 | 4 | |
| 3A | | Bulkhead Fitting (2 per pack) | | | | | |
| 3B | | Gasket (4 per pack) | | | | | |
| 3C | | Hex Nut (2 per pack) | | | | | |
| 4 | 1118 | Wrench and Hole Saw Kit | 1 | 1 | 1 | 1 | |
| 4A | | 3/8" Drive Lug Spanner Wrench | | | | | |
| 4B | | 2 3/8" Hole Saw with Arbor | | | | | |
| 4C | | 3/8" Drive Socket Wrench | | | | | |

NOTE: WRENCH AND HOLE SAW KIT MUST BE PURCHASE SEPARATELY; PORTABLE DRILL AND (2) 3/8" DRIVE RACHETS NOT PROVIDED.