

**NOZZLE SCHEDULE**

ITEM	SIZE	RATING	TYPE	MATL	REMARKS	NOTES
A	3"	N.P.T.	W.F.	C.S.	-	EMERGENCY VENT OPENING
B	2"	N.P.T.	W.F.	C.S.	-	-

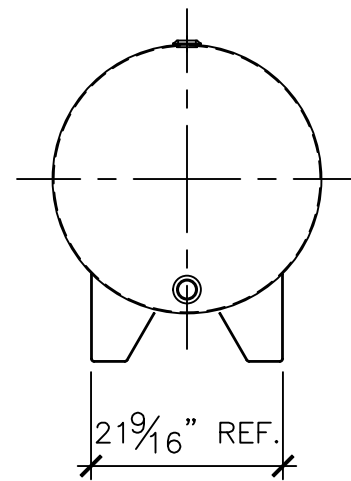

**LEFT SIDE**

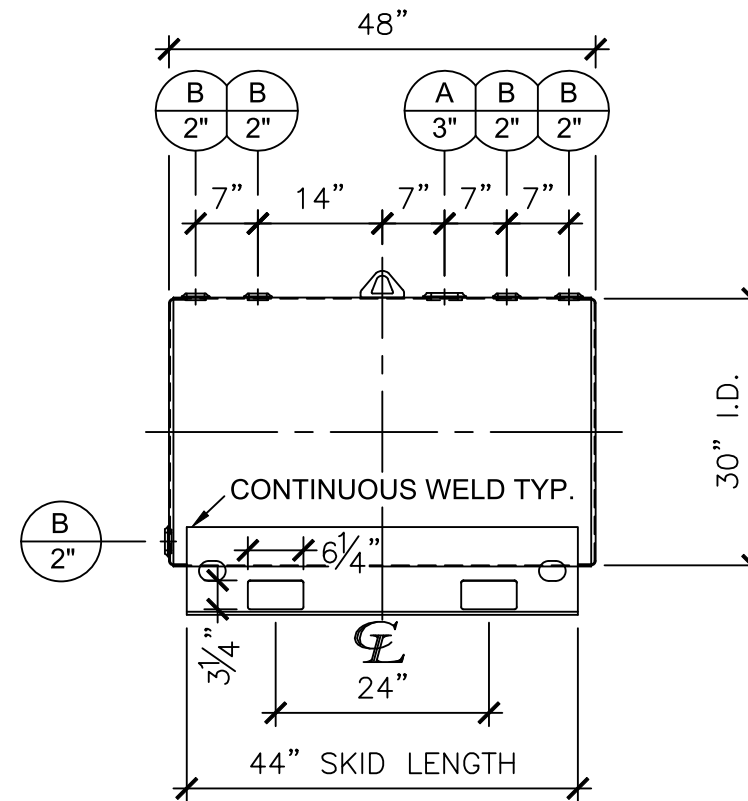

**FRONT VIEW**

**NOTES:**

- A. Material: H.R. Carbon Steel.
- B. Design Pressure: Atmospheric.
- C. Design Temperature: Ambient.
- D. Built & Labeled per U.L. Spec. #142.
- E. Exterior: Gray primer included; see Sales Order for top coat.
- F. All Fittings to be protected for shipment.
- G. Customer to verify nozzle sizes, locations, and quantities.
- H. Saddles/skids may require shimming or grouting during installation.

APPROVAL FOR CONSTRUCTION SCHEDULE A - MASTER TERMS & CONDITION OF SALE*		SALES ORDER: -		WEIGHT (LBS): 400	
<input type="checkbox"/> APPROVED AS DRAWN.		All units inches unless stated otherwise			
<input type="checkbox"/> APPROVED WITH NOTED CHANGES, CONSTRUCTION WILL BE SCHEDULED WHEN SIGNED DRAWING AND CONFIRMED ORDER ARE RECEIVED.		www.clarionmunicipal.com			
SIGNATURE: _____		DESCRIPTION: 150 GALLON 30" I.D. x 4'-0" O.A.L. SINGLE WALL SKID TANK			
DATE: _____		CUSTOMER: -		P.O.#: -	
DATE: 03/14/23		SCALE:		DWG.# NB00150SWS03012G	
				DRAWN BY: WR	
				SHEET 1 OF 1	