

NOZZLE SCHEDULE

ITEM	SIZE	RATING	TYPE	MATL	REMARKS	NOTES
A	3"	N.P.T.	W.F.	C.S.	PRIMARY	EMERGENCY VENT OPENING
B	3"	N.P.T.	H.CPL.	C.S.	SECONDARY	EMERGENCY VENT OPENING
C	2"	N.P.T.	CPL.	C.S.	-	INTERSTICE MONITOR
D	2"	N.P.T.	W.F.	C.S.	-	-

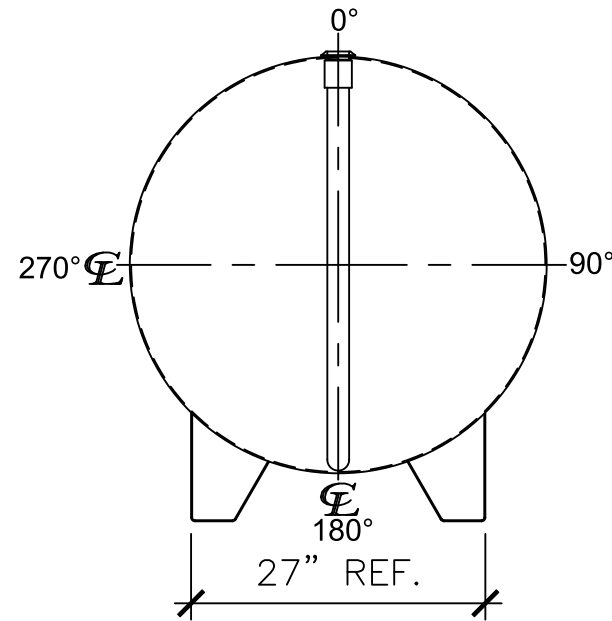

LEFT SIDE

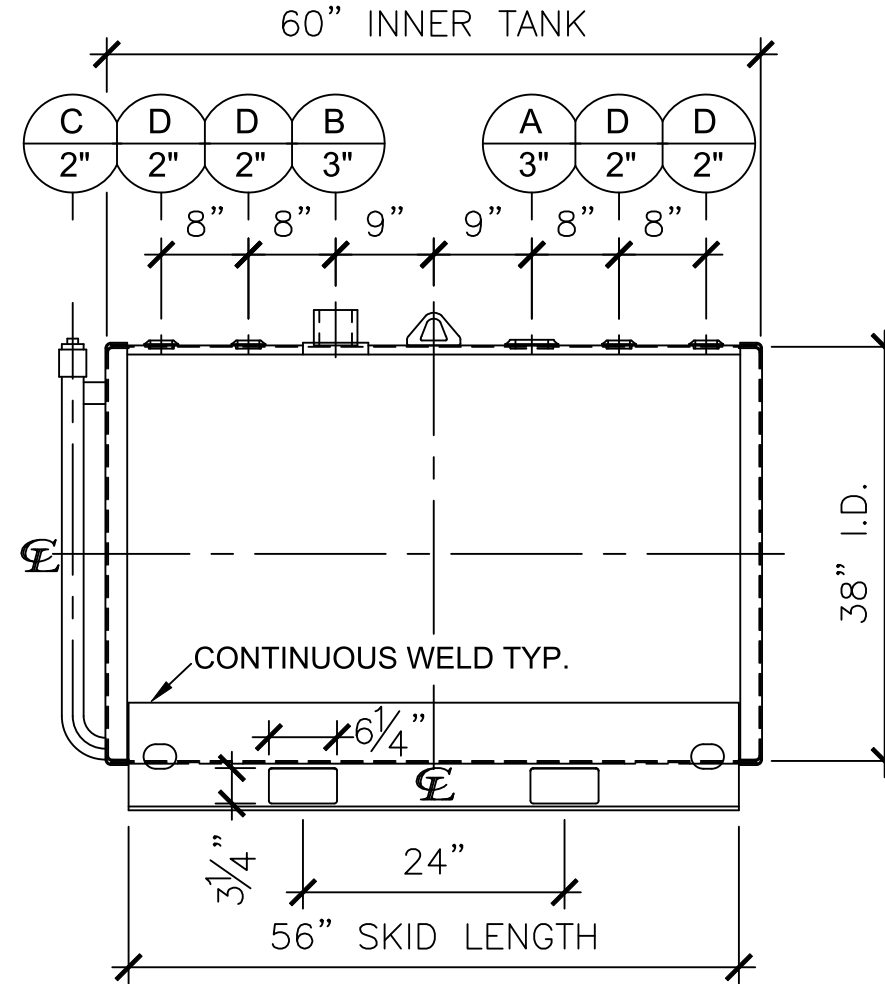

FRONT VIEW

NOTES:

- A. Material: H.R. Carbon Steel.
- B. Design Pressure: Atmospheric.
- C. Design Temperature: Ambient.
- D. Built & labeled per U.L. spec. #142.
- E. Exterior: Gray primer included; see Sales Order for top coat.
- F. All fittings to be protected for shipment.
- G. Customer to verify nozzle sizes, locations, and quantities.
- H. Saddles/skids may require shimming or grouting during installation.

APPROVAL FOR CONSTRUCTION SCHEDULE A - MASTER TERMS & CONDITION OF SALE*		SALES ORDER:		WEIGHT (LBS): 1000
<input type="checkbox"/> APPROVED AS DRAWN.		 www.clarionmunicipal.com		
<input type="checkbox"/> APPROVED WITH NOTED CHANGES. CONSTRUCTION WILL BE SCHEDULED WHEN SIGNED DRAWING AND CONFIRMED ORDER ARE RECEIVED.		DESCRIPTION: 300 GALLON 38" I.D. x 5'-0" O.A.L. DOUBLE WALL SKID TANK		
SIGNATURE: _____ DATE: _____		CUSTOMER: _____		P.O.# _____
DATE: 06/07/23	SCALE:	DWG.# NB00300DWS03812G	DRAWN BY: WR SHEET 1 OF 1	