

NOZZLE SCHEDULE

ITEM	SIZE	RATING	TYPE	MATL	REMARKS	NOTES
A	2"	N.P.T.	W.F.	C.S.	-	-

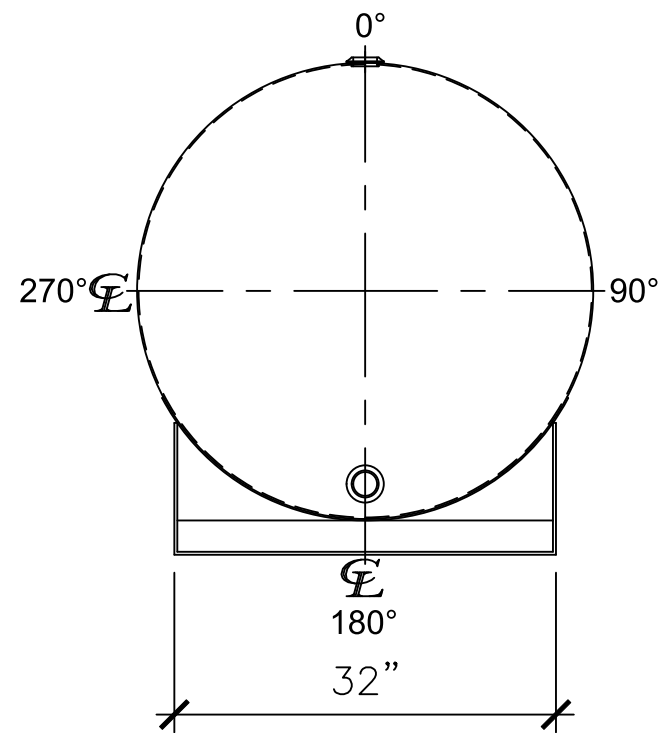

LEFT SIDE

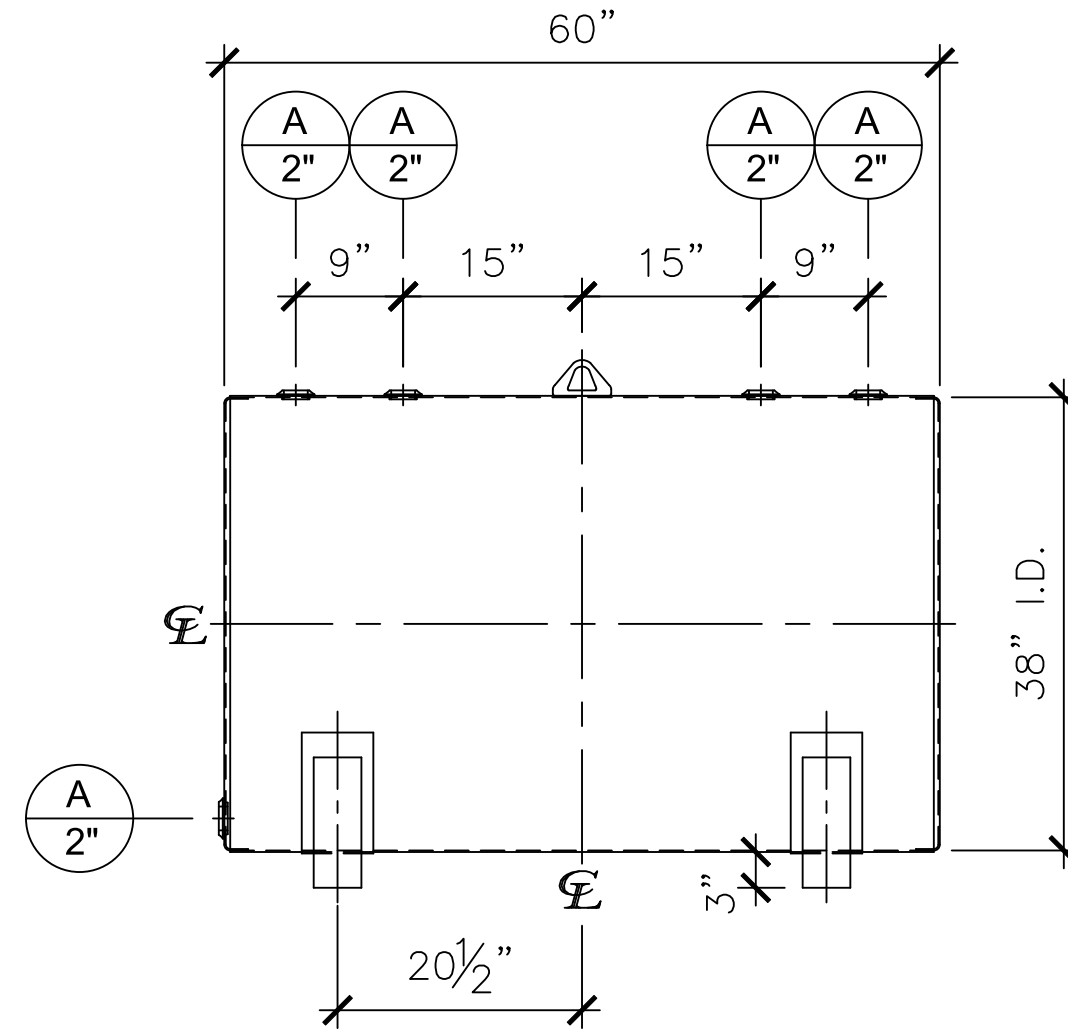

FRONT VIEW

NOTES:

- A. Material: H.R. Carbon Steel.
- B. Design Pressure: Atmospheric.
- C. Design Temperature: Ambient.
- D. Exterior: Gray primer included; see Sales Order for top coat.
- E. All Fittings to be protected for shipment.
- F. Customer to verify nozzle sizes, locations, and quantities.
- G. Saddles/skids may require shimming or grouting during installation.

APPROVAL FOR CONSTRUCTION SCHEDULE A - MASTER TERMS & CONDITION OF SALE* <input type="checkbox"/> APPROVED AS DRAWN. <input type="checkbox"/> APPROVED WITH NOTED CHANGES. CONSTRUCTION WILL BE SCHEDULED WHEN SIGNED DRAWING AND CONFIRMED ORDER ARE RECEIVED. SIGNATURE: _____ DATE: _____		SALES ORDER: - www.clarionmunicipal.com DESCRIPTION: 300 Gallon 38" I.D. x 5'-0" O.A.L. Single Wall Farm Bracket Tank CUSTOMER: - P.O.# - DATE: 04/12/23 SCALE: DWG.# NB00300FTB03812G DRAWN BY: WR SHEET 1 OF 1	WEIGHT (LBS): 455 All units inches unless stated otherwise
---	--	---	---