

NOZZLE SCHEDULE

ITEM	SIZE	RATING	TYPE	MATL	REMARKS	NOTES
A	2"	N.P.T.	W.F.	C.S.	-	-

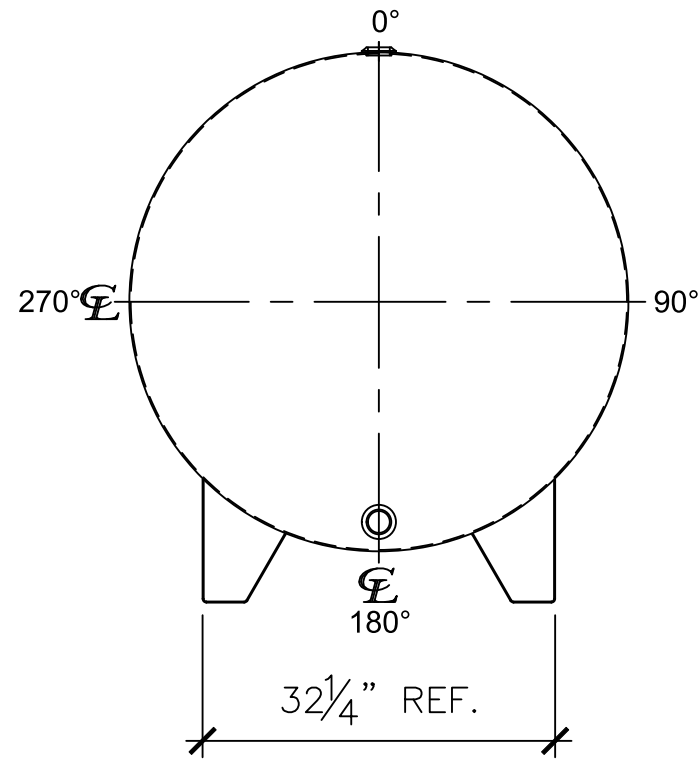

LEFT SIDE

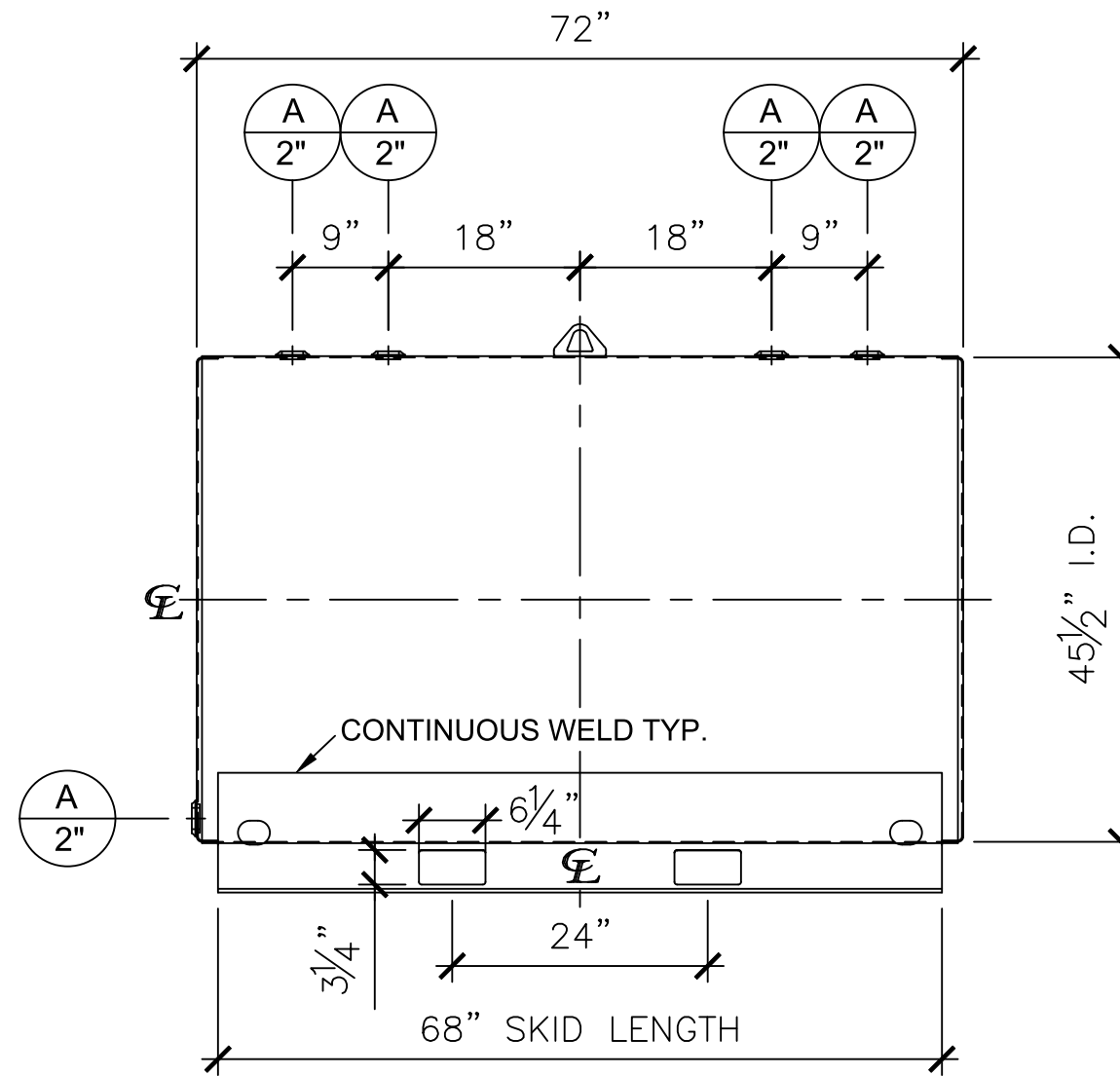

FRONT VIEW

NOTES:

- A. Material: H.R. Carbon Steel.
- B. Design Pressure: Atmospheric.
- C. Design Temperature: Ambient.
- D. Exterior: Gray primer included; see Sales Order for top coat.
- E. All Fittings to be protected for shipment.
- F. Customer to verify nozzle sizes, locations, and quantities.
- G. Saddles/skids may require shimming or grouting during installation.

APPROVAL FOR CONSTRUCTION SCHEDULE A - MASTER TERMS & CONDITION OF SALE*		SALES ORDER: -		WEIGHT (LBS): 550	
<input type="checkbox"/> APPROVED AS DRAWN. <input type="checkbox"/> APPROVED WITH NOTED CHANGES, CONSTRUCTION WILL BE SCHEDULED WHEN SIGNED DRAWING AND CONFIRMED ORDER ARE RECEIVED.		All units inches unless stated otherwise			
SIGNATURE: _____ DATE: _____		www.clarionmunicipal.com			
DESCRIPTION: 500 Gallon 45 1/2" I.D. x 6'-0" O.A.L. Single Wall Farm Skid Tank					
CUSTOMER: -				P.O.# -	
DATE: 05/11/23	SCALE:	DWG.# NB00500FTS45512G	DRAWN BY: WR SHEET 1 OF 1		