

NOZZLE SCHEDULE						
ITEM	SIZE	RATING	TYPE	MATL	REMARKS	NOTES
A	2"	N.P.T.	W.F.	C.S.	-	-

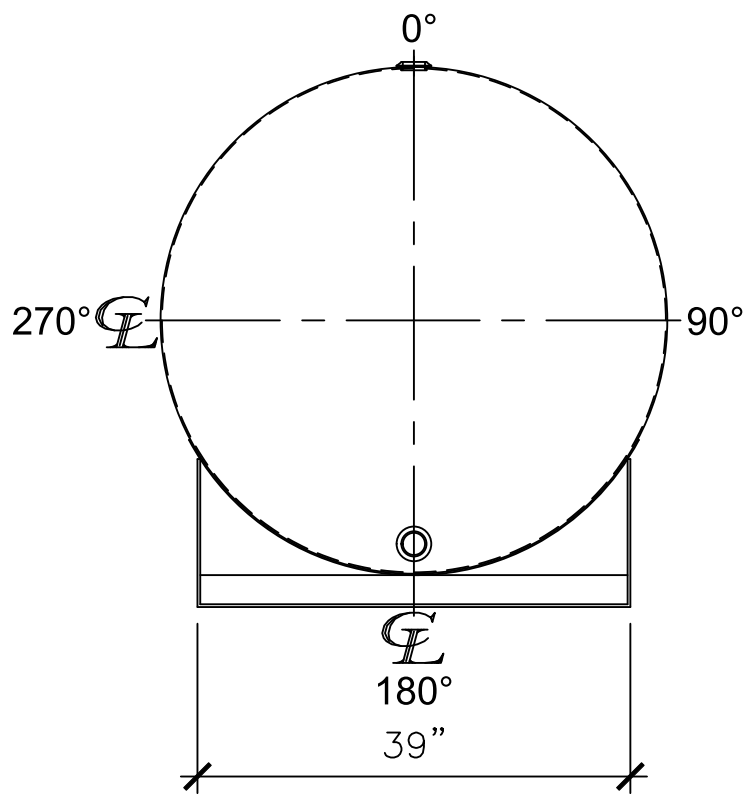

LEFT SIDE

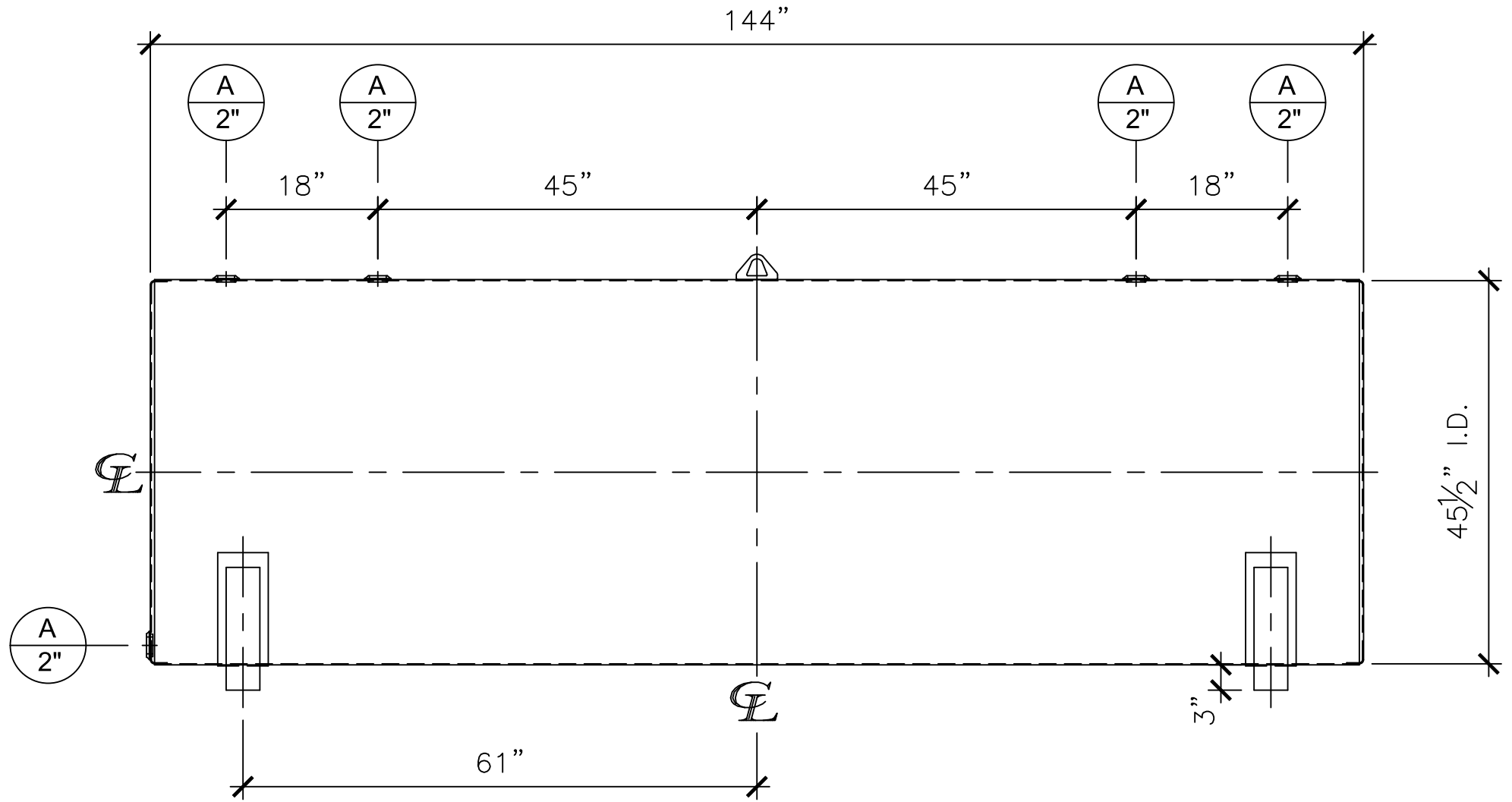

FRONT VIEW

**NOTES:**

- A. Material: H.R. Carbon Steel.
- B. Design Pressure: Atmospheric.
- C. Design Temperature: Ambient.
- D. Exterior: Gray primer included; see Sales Order for top coat.
- E. All Fittings to be protected for shipment.
- F. Customer to verify nozzle sizes, locations, and quantities.
- G. Saddles/skids may require shimming or grouting during installation.

APPROVAL FOR CONSTRUCTION SCHEDULE A - MASTER TERMS & CONDITION OF SALE*			SALES ORDER: -		WEIGHT (LBS): 1050
<input type="checkbox"/> APPROVED AS DRAWN. <input type="checkbox"/> APPROVED WITH NOTED CHANGES, CONSTRUCTION WILL BE SCHEDULED WHEN SIGNED DRAWING AND CONFIRMED ORDER ARE RECEIVED.			 www.clarionmunicipal.com		
SIGNATURE: _____ DATE: _____					
DESCRIPTION: 1000 Gallon 45 1/2" I.D. x 12'-0" O.A.L. Single Wall Farm Bracket Tank					
CUSTOMER: -				P.O.# -	
DATE: 04/17/23	SCALE:	DWG.# NB01000FTB45512G	DRAWN BY: WR SHEET 1 OF 1		