

NOZZLE SCHEDULE

ITEM	SIZE	RATING	TYPE	MATL.	REMARKS	NOTES
A	4"	N.P.T.	W.F.	C.S.	-	-
B	2"	N.P.T.	M.F.	C.S.	-	MONITORING PORT

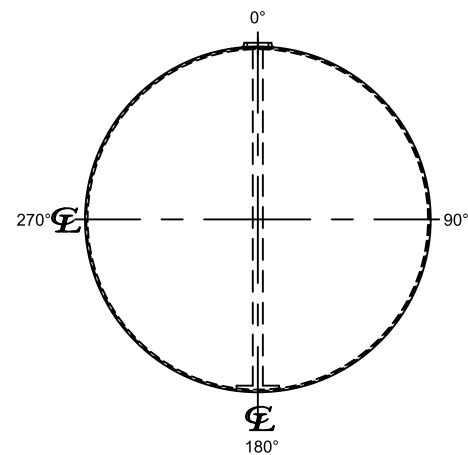

LEFT SIDE

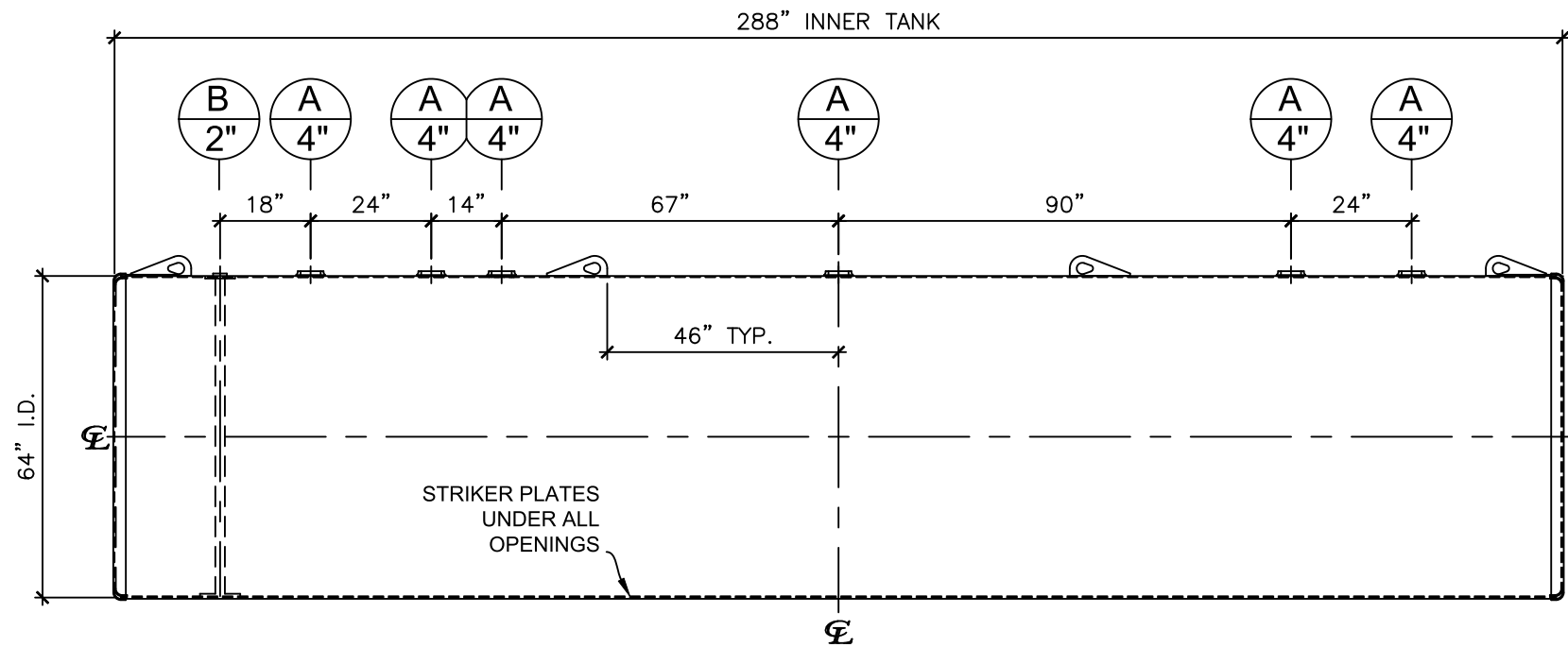

FRONT VIEW

NOTES:

- A. Material: H.R. Carbon Steel.
- B. Design Pressure: Atmospheric.
- C. Design Temperature: Ambient.
- D. Built & labeled per U.L. #58, UL 1746 and ACT100 specs.
- E. Exterior: Blast & apply min.100 mils DFT Fiberglass.
- F. Seal welded striker plates under all openings.
- G. All fittings to be protected for shipment.
- H. Customer to verify nozzle sizes, locations, and quantities.

APPROVAL FOR CONSTRUCTION
SCHEDULE A - MASTER TERMS &
CONDITION OF SALE*

- APPROVED AS DRAWN.
- APPROVED WITH NOTED CHANGES.
CONSTRUCTION WILL BE SCHEDULED
WHEN SIGNED DRAWING AND
CONFIRMED ORDER ARE RECEIVED.

SIGNATURE: _____

DATE: _____

SALES ORDER:

WEIGHT (LBS): 6,672



www.clarionmunicipal.com

All units inches
unless stated
otherwise

DESCRIPTION:
**4000 GALLON 64" I.D. x 24'-0" O.A.L. DOUBLE WALL
ACT-100 TANK**

CUSTOMER: _____ P.O.# _____

DATE: 06/26/23 SCALE: _____ DWG.# NB04000DWA064250 DRAWN BY: WR
SHEET 1 OF 1