

NOZZLE SCHEDULE

ITEM	SIZE	RATING	TYPE	MATL	PROJ. IN	PROJ. OUT	REMARKS	NOTES
A	20"	U.L.	M.W.	C.S.	STD.	STD.	SINGLE PUNCHED	TIGHT BOLTED
B	8"	N.P.T.	H.CPL.	C.S.	STD.	STD.	-	EMERGENCY VENT OPENING
C	2"	N.P.T.	W.F.	C.S.	STD.	STD.	-	-
D	4"	N.P.T.	W.F.	C.S.	STD.	STD.	-	-
E	6"	N.P.T.	H.CPL.	C.S.	STD.	STD.	-	-

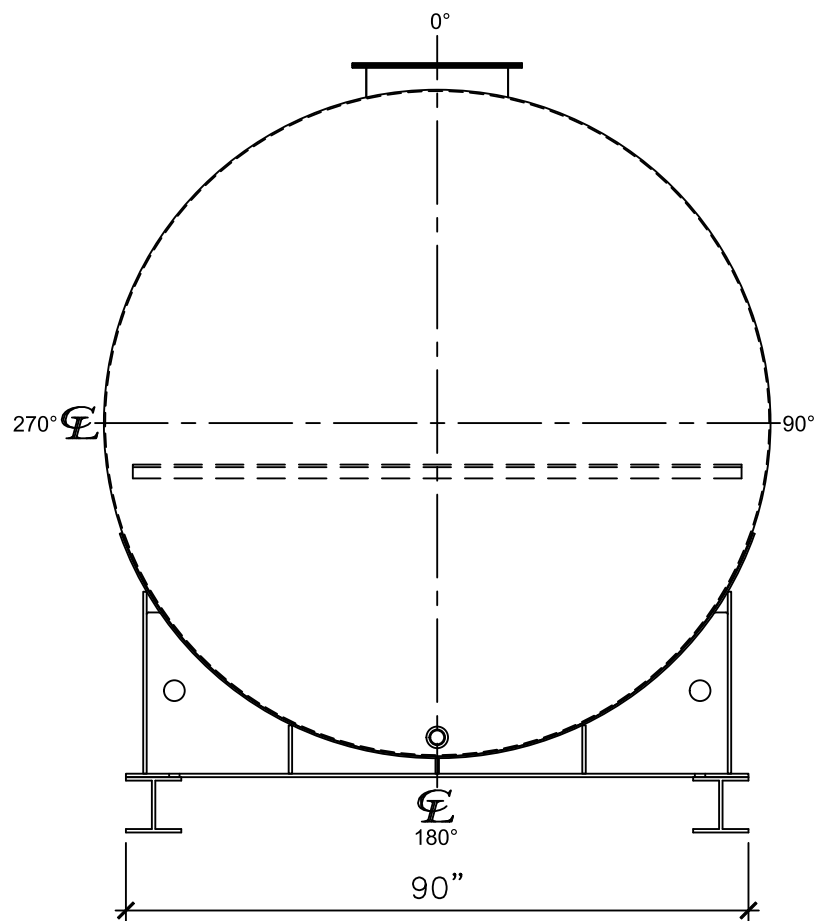

LEFT SIDE

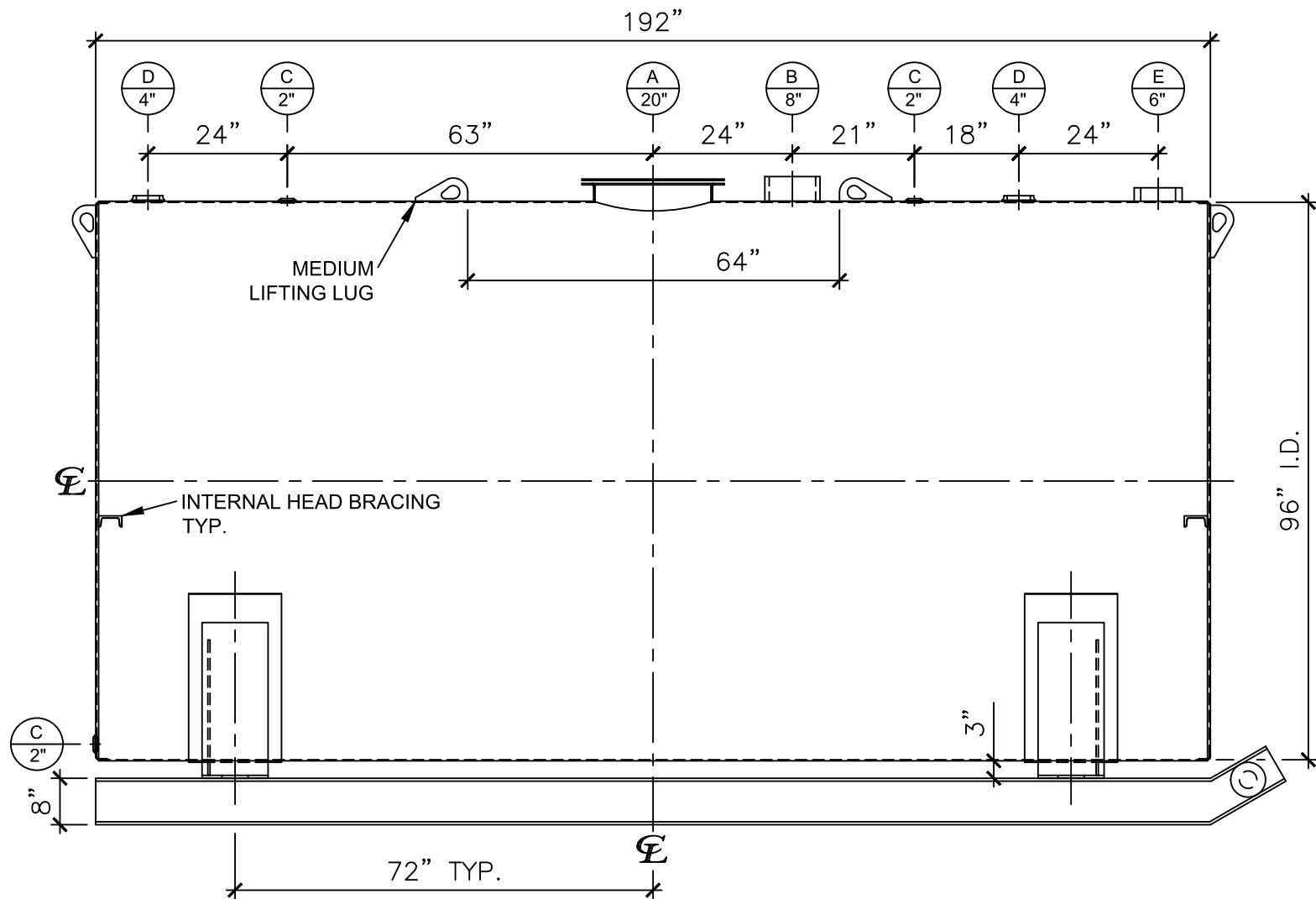

FRONT VIEW

NOTES:

- A. Material: H.R. Carbon Steel.
- B. Design Pressure: Atmospheric.
- C. Design Temperature: Ambient.
- D. Built & labeled per U.L. spec. #142.
- E. Exterior: Gray primer included; see Sales Order for top coat.
- F. All fittings to be protected for shipment.
- G. Customer to verify nozzle sizes, locations, and quantities.
- H. Saddles/skids may require shimming or grouting during installation.

APPROVAL FOR CONSTRUCTION SCHEDULE A - MASTER TERMS & CONDITION OF SALE*		SALES ORDER:		WEIGHT (LBS): 6675
<input type="checkbox"/> APPROVED AS DRAWN.		All units inches unless stated otherwise		
<input type="checkbox"/> APPROVED WITH NOTED CHANGES. CONSTRUCTION WILL BE SCHEDULED WHEN SIGNED DRAWING AND CONFIRMED ORDER ARE RECEIVED.		ONE CLARION www.clarionmunicipal.com		
SIGNATURE: _____ DATE: _____		DESCRIPTION: 6000 GALLON 96" I.D. x 16'-0" O.A.L. SINGLE WALL SKID TANK		
CUSTOMER: _____		P.O.# _____		DRAWN BY: WR
DATE: 06/05/23	SCALE: _____	DWG.# NB06000SWS096250	SHEET 1 OF 1	