

NOZZLE SCHEDULE

ITEM	SIZE	RATING	TYPE	MATL.	PROJ. IN	PROJ. OUT	REMARKS	NOTES
A	4"	N.P.T.	W.F.	C.S.	STD.	STD.	-	-
B	2"	N.P.T.	M.F.	C.S.	STD.	STD.	-	MONITORING PORT

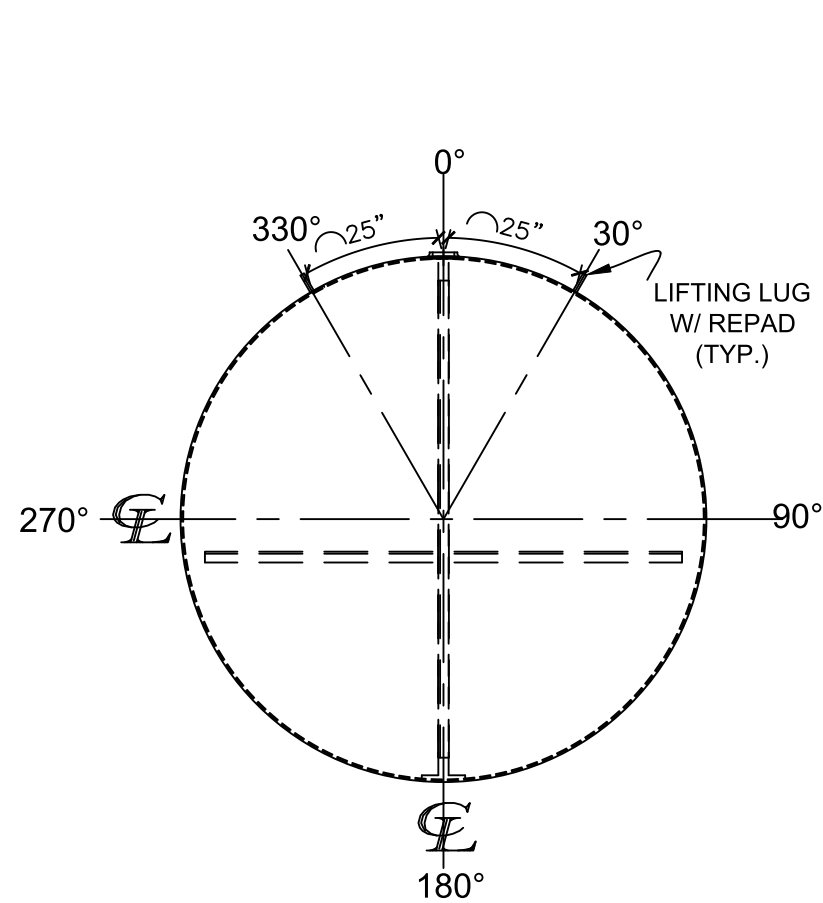

LEFT SIDE

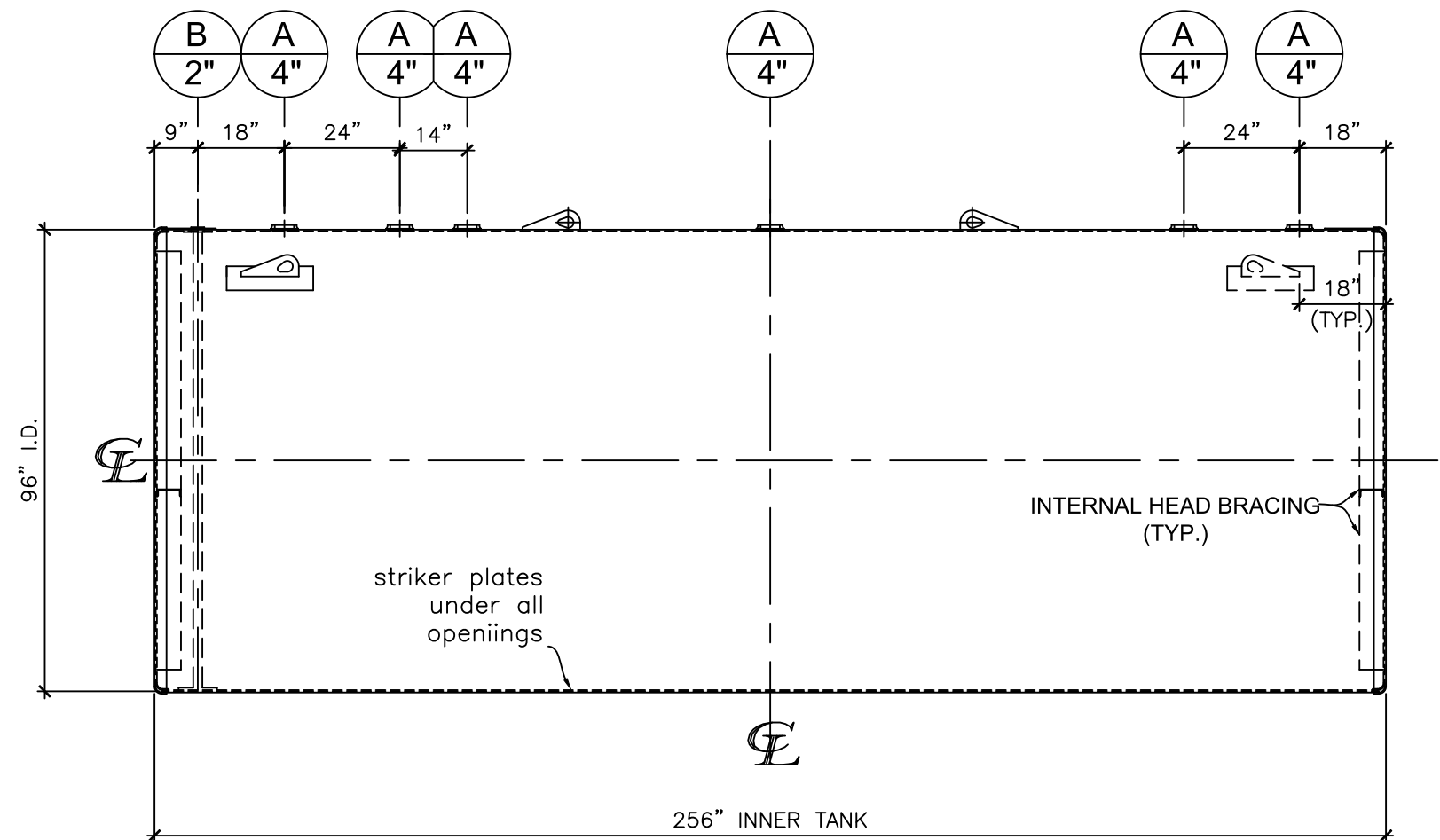

FRONT VIEW

NOTES:

- A. Quantity:
- B. Material: H.R. Carbon Steel.
- C. Design Pressure: Atmospheric.
- D. Design Temperature: Ambient.
- E. Built & labeled per U.L. #58, UL 1746 and ACT100 specs.
- F. Exterior: Blast & apply min.100 mils DFT Fiberglass.
- G. Seal welded striker plates under all openings.
- H. All fittings to be protected for shipment.
- I. Customer to verify nozzle sizes, locations and quantities.

*All pages of this Schedule A are incorporated by reference and are a part of the additional terms of the Master Terms & Conditions of Sale.

APPROVAL FOR CONSTRUCTION SCHEDULE A - MASTER TERMS & CONDITION OF SALE*		SALES ORDER: -		WEIGHT (LBS): 12,500	
<input type="checkbox"/> APPROVED AS DRAWN.		www.clarionmunicipal.com			
<input type="checkbox"/> APPROVED WITH NOTED CHANGES. CONSTRUCTION WILL BE SCHEDULED WHEN SIGNED DRAWING AND CONFIRMED ORDER ARE RECEIVED.					
SIGNATURE: _____		DESCRIPTION: 8000 Gallon 96" I.D. x 21'-4" O.A.L. Double Wall ACT-100 Tank			
DATE: _____		CUSTOMER: _____		P.O.# _____	
DATE: 10/10/2022	SCALE: _____	DWG# NB08000DWA096250	DRAWN BY: SHEET 1 OF 1		