

### NOZZLE SCHEDULE

ITEM	SIZE	RATING	TYPE	MATL	PROJ. IN	PROJ. OUT	REMARKS	NOTES
A	20"	U.L.	MANWAY	C.S.	STD.	STD.	SINGLE PUNCHED	TIGHT BOLTED
B	8"	N.P.T.	H. CPL.	C.S.	STD.	STD.	PRIMARY	EMERGENCY VENT OPENING
C	8"	N.P.T.	H. CPL.	C.S.	STD.	STD.	SECONDARY	EMERGENCY VENT OPENING
D	2"	N.P.T.	M.F.	C.S.	STD.	STD.	-	MONITORING PORT
E	4"	N.P.T.	W.F.	C.S.	STD.	STD.	-	-
F	2"	N.P.T.	W.F.	C.S.	STD.	STD.	-	-
G	6"	N.P.T.	H.CPL.	C.S.	STD.	STD.	-	-

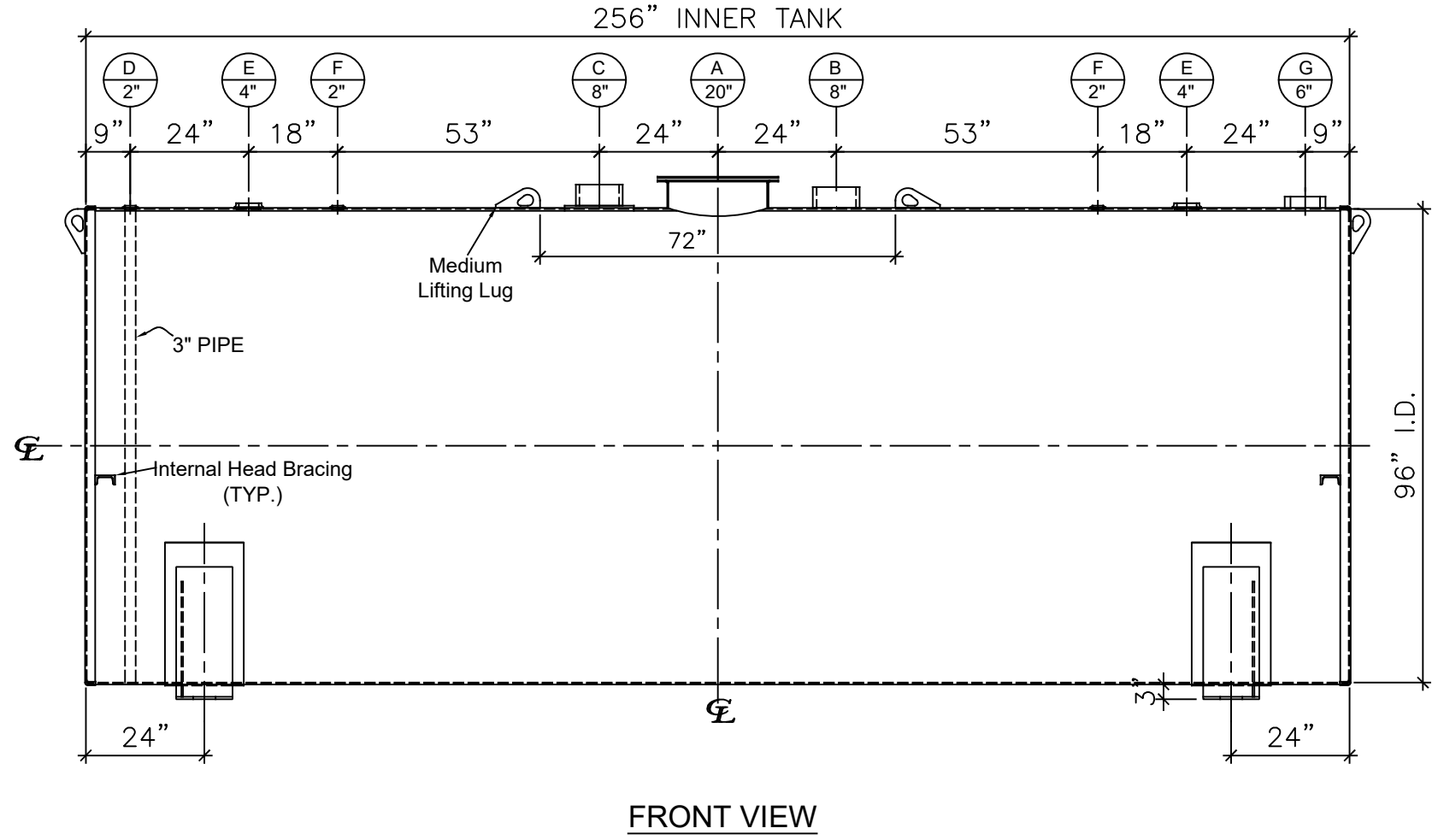
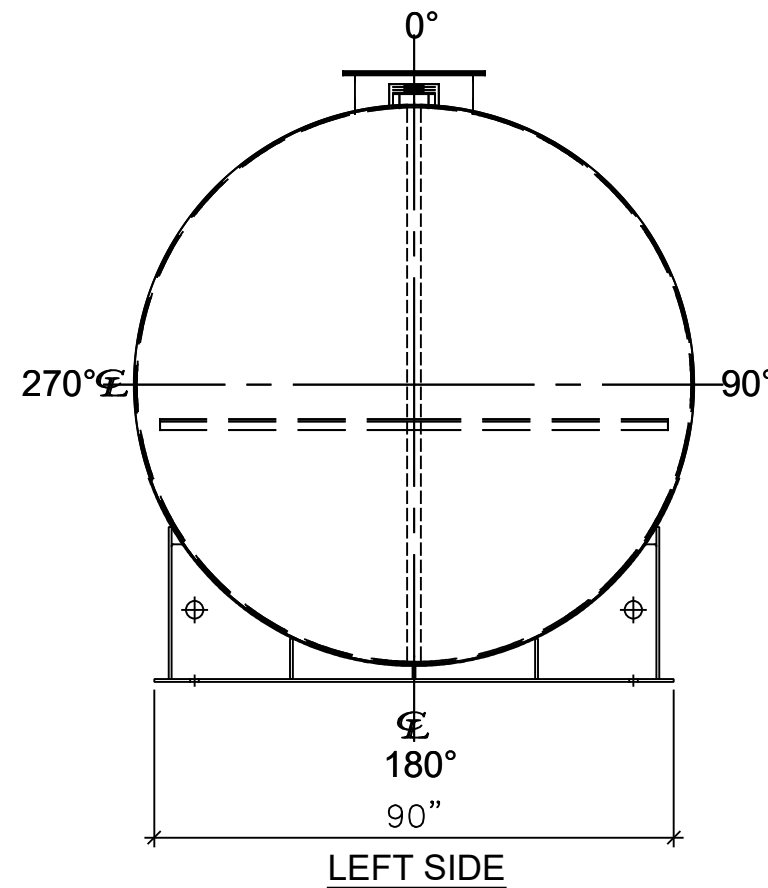

**NOTES:**

- A. Material: H.R. Carbon Steel.
- B. Design Pressure: Atmospheric.
- C. Design Temperature: Ambient.
- D. Built & labeled per U.L. #142 & SwRI 97-04 specifications.
- E. Exterior: Blast & apply one shop coat WHITE enamel.
- F. All fittings to be protected for shipment.
- G. Customer to verify nozzle sizes, locations and quantities.
- H. Saddles/skids may require shimming or grouting during installation.

APPROVAL FOR CONSTRUCTION SCHEDULE A - MASTER TERMS & CONDITION OF SALE		<b>QUOTE:</b>	
<input type="checkbox"/> APPROVED AS DRAWN.		 www.clarionmunicipal.com	
<input type="checkbox"/> APPROVED WITH NOTED CHANGES. CONSTRUCTION WILL BE SCHEDULED WHEN SIGNED DRAWING AND CONFIRMED ORDER ARE RECEIVED.		All units inches unless stated otherwise	
SIGNATURE: _____		<b>DESCRIPTION:</b> 8000 Gallon 96" I.D. x 21'-4" O.A.L. Double Wall Flameshield Tank	
DATE: _____		CUSTOMER: _____	P.O.# _____
DATE: 3/8/2023	SCALE: _____	DWG.# NB08000FSD096250	DRAWN BY: AJC
			SHEET 1 OF 1