

NOZZLE SCHEDULE

ITEM	SIZE	RATING	TYPE	MATL	REMARKS	NOTES
A	20"	U.L.	M.W.	C.S.	SINGLE PUNCHED	TIGHT BOLTED
B	8"	N.P.T.	H. CPL.	C.S.	PRIMARY	EMERGENCY VENT OPENING
C	8"	N.P.T.	H. CPL.	C.S.	SECONDARY	EMERGENCY VENT OPENING
D	2"	N.P.T.	M.F.	C.S.	-	MONITORING PORT
E	4"	N.P.T.	W.F.	C.S.	-	-
F	6"	N.P.T.	H.CPL.	C.S.	-	-
G	2"	N.P.T.	W.F.	C.S.	-	-

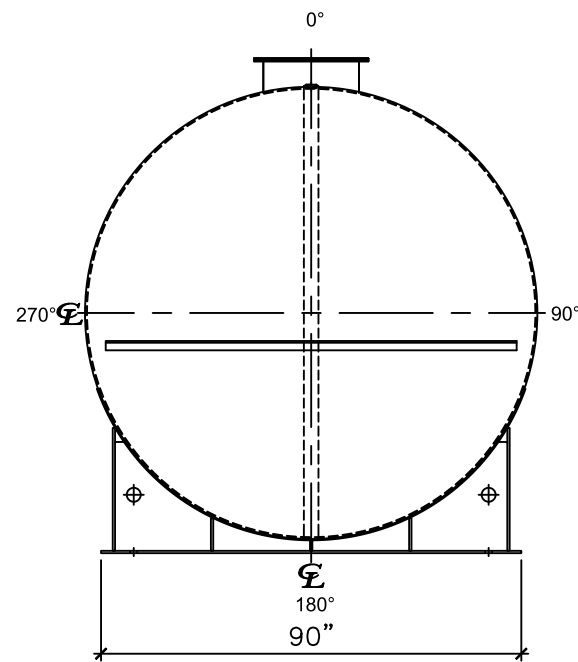

LEFT SIDE

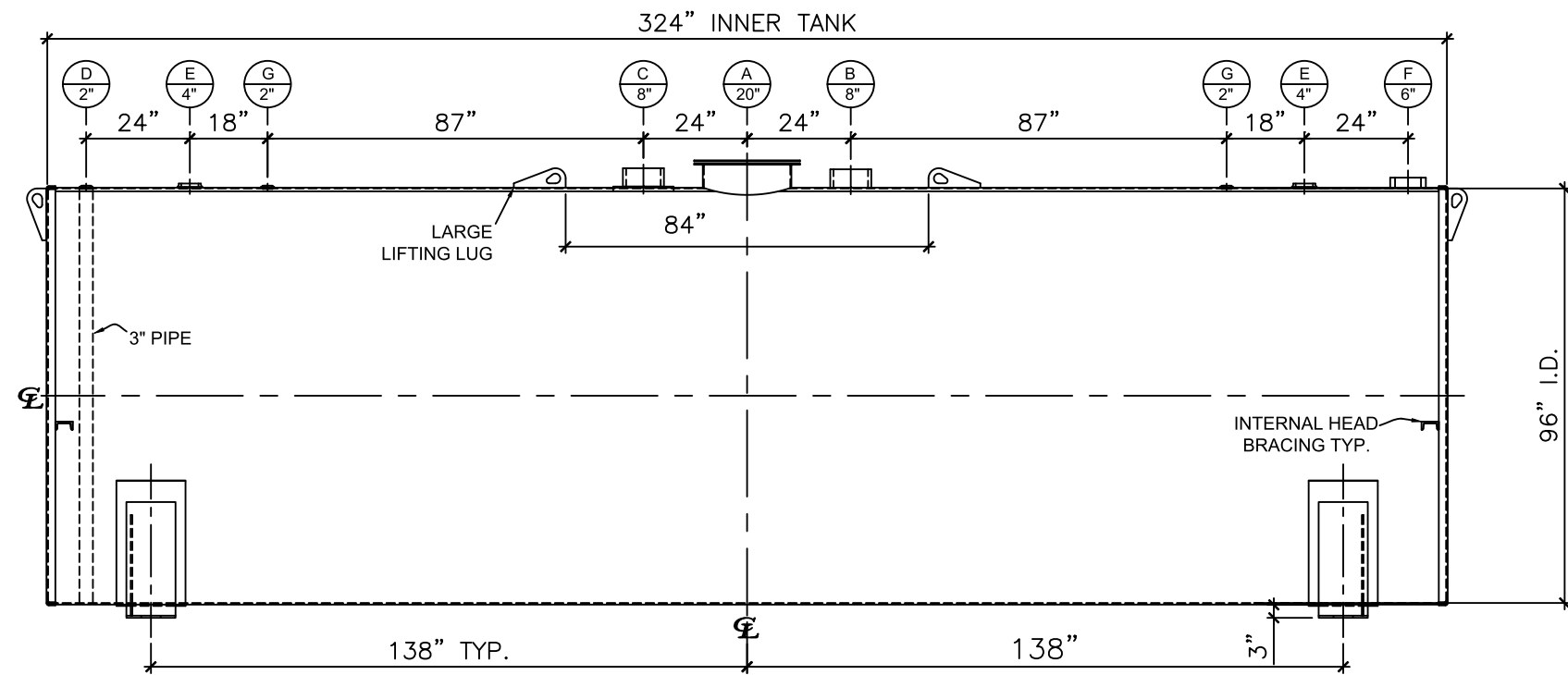

FRONT VIEW

NOTES:

- A. Material: H.R. Carbon Steel.
- B. Design Pressure: Atmospheric.
- C. Design Temperature: Ambient.
- D. Built & Labeled per U.L. Spec. #142.
- E. Exterior: Gray primer included; see Sales Order for top coat.
- F. All Fittings to be protected for shipment.
- G. Customer to verify nozzle sizes, locations, and quantities.
- H. Saddles/skids may require shimming or grouting during installation.

APPROVAL FOR CONSTRUCTION
SCHEDULE A - MASTER TERMS &
CONDITION OF SALE

APPROVED AS DRAWN.

APPROVED WITH NOTED CHANGES,
CONSTRUCTION WILL BE SCHEDULED
WHEN SIGNED DRAWING AND
CONFIRMED ORDER ARE RECEIVED.

SIGNATURE: _____

DATE: _____

SALES ORDER: -

WEIGHT (LBS): 14500

ONE
CLARION
www.clarionmunicipal.com

DESCRIPTION:
10000 GALLON 96" I.D. X 27'-0" O.A.L. DOUBLE WALL
SADDLE TANK

CUSTOMER: - P.O.#: -

DATE: 10/10/22 SCALE: DWG.# NB10000DWB096250 DRAWN BY: TC

SHEET 1 OF 1