

NOZZLE SCHEDULE

ITEM	SIZE	RATING	TYPE	MATL.	PROJ. IN	PROJ. OUT	REMARKS	NOTES
A	4"	N.P.T.	W.F.	C.S.	STD.	STD.	-	-
B	2"	N.P.T.	M.F.	C.S.	STD.	STD.	-	MONITORING PORT

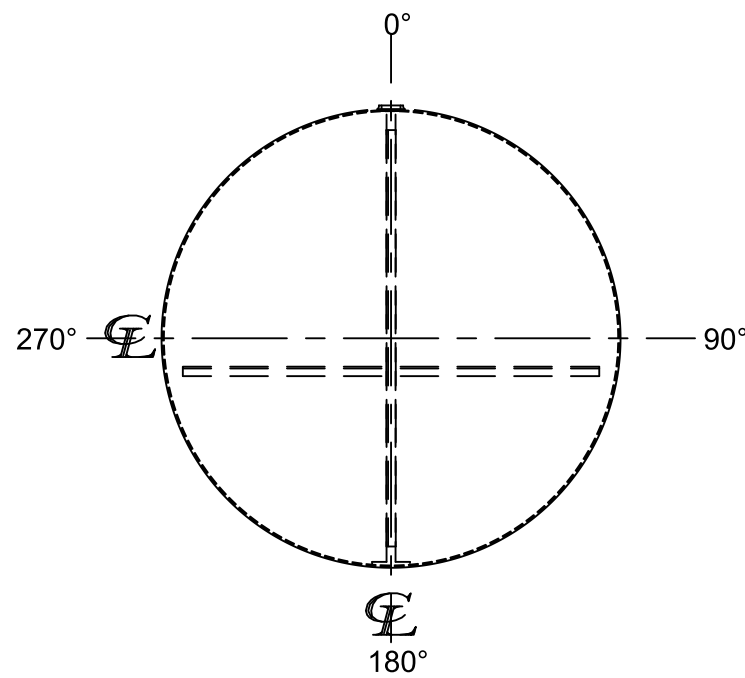

LEFT SIDE

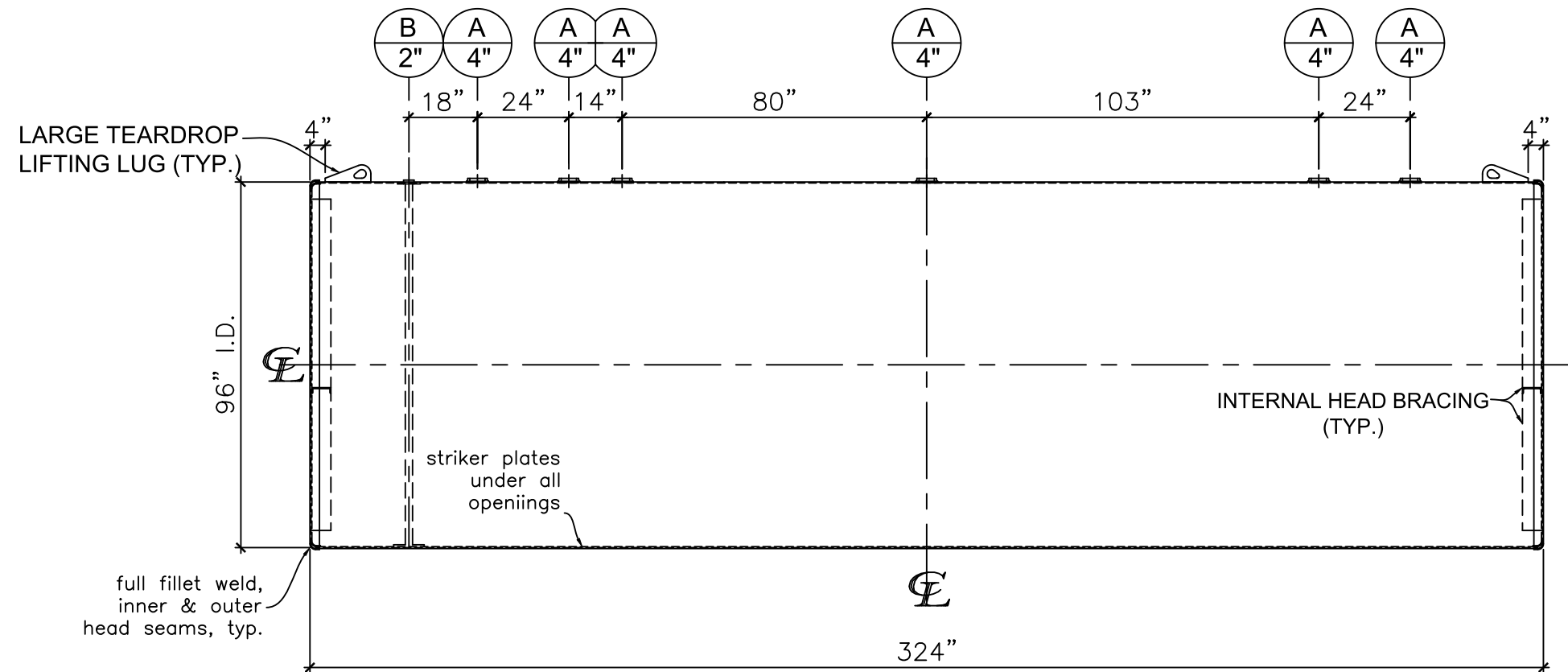

FRONT VIEW

NOTES:

- A. Quantity:
- B. Material: H.R. Carbon Steel.
- C. Design Pressure: Atmospheric.
- D. Design Temperature: Ambient.
- E. Built & labeled per U.L. #58 and #1746 Part 3.
- F. Exterior: Min.100 mils FBG jacketed dual-wall PermatankK
- I. Seal welded striker plates under all openings.
- J. Integral lifting plugs provided.
- K. All fittings to be protected for shipment.
- L. Customer to verify nozzle sizes, locations and quantities.

*All pages of this Schedule A are incorporated by reference and are a part of the additional terms of the Master Terms & Conditions of Sale.

APPROVAL FOR CONSTRUCTION SCHEDULE A - MASTER TERMS & CONDITION OF SALE*		SALES ORDER: -		WEIGHT (LBS): 9,324	
<input type="checkbox"/> APPROVED AS DRAWN.		www.clarionmunicipal.com			
<input type="checkbox"/> APPROVED WITH NOTED CHANGES. CONSTRUCTION WILL BE SCHEDULED WHEN SIGNED DRAWING AND CONFIRMED ORDER ARE RECEIVED.					
SIGNATURE: _____		DESCRIPTION: 10,000 Gallon 96" I.D. x 27'-0" O.A.L. Double Wall Permatank			
DATE: _____		CUSTOMER:		P.O.#	
DATE: 10/10/2022	SCALE:	DWG.# NB10000PRM096250	DRAWN BY: SHEET 1 OF 1		