

NOZZLE SCHEDULE								
ITEM	SIZE	RATING	TYPE	MATL	PROJ. IN	PROJ. OUT	REMARKS	NOTES
A	20"	U.L.	M.W.	C.S.	STD.	STD.	SINGLE PUNCHED	TIGHT BOLTED
B	8"	N.P.T.	H. CPL.	C.S.	STD.	STD.	EMERGENCY VENT OPENING	-
C	2"	N.P.T.	W.F.	C.S.	STD.	STD.	-	-
D	4"	N.P.T.	W.F.	C.S.	STD.	STD.	-	-
E	6"	N.P.T.	H.CPL.	C.S.	STD.	STD.	-	-

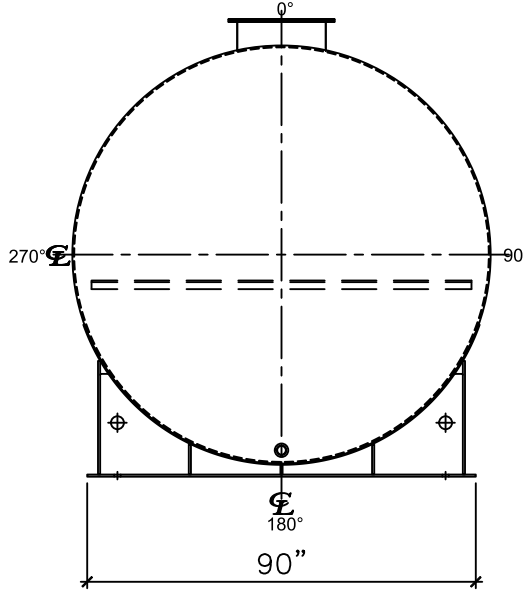

LEFT SIDE

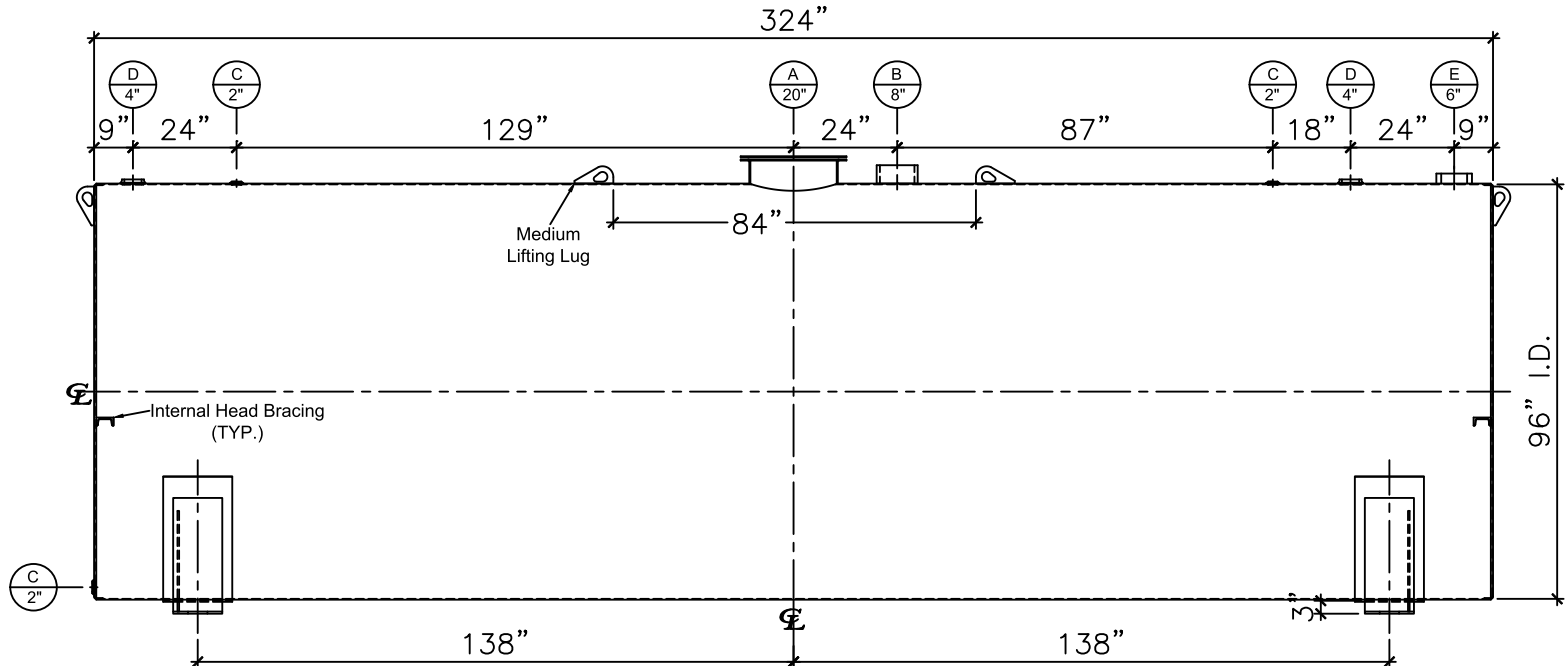

FRONT VIEW

NOTES:

- A. Material: H.R. Carbon Steel.
- B. Design Pressure: Atmospheric.
- C. Design Temperature: Ambient.
- D. Built & Labeled per U.L. Spec. #142.
- E. Exterior: Gray primer included; see Sales Order for top coat.
- F. All Fittings to be protected for shipment.
- G. Customer to verify nozzle sizes, locations, and quantities.
- H. Saddles/skids may require shimming or grouting during installation.

APPROVAL FOR CONSTRUCTION
SCHEDULE A - MASTER TERMS &
CONDITION OF SALE

APPROVED AS DRAWN.

APPROVED WITH NOTED CHANGES.
CONSTRUCTION WILL BE SCHEDULED
WHEN SIGNED DRAWING AND
CONFIRMED ORDER ARE RECEIVED.

SIGNATURE: _____

DATE: _____

SALES ORDER: -

WEIGHT (LBS): 10250

ONE CLARION
www.clarionmunicipal.com

All units inches unless stated otherwise

DESCRIPTION:
10000 GALLON 96" I.D. X 27'-0" O.A.L. SINGLE WALL
SADDLE TANK

CUSTOMER: - P.O.#: -

DATE: 10/10/22 SCALE: DWG.# NB10000SWB096250

DRAWN BY: TC
SHEET 1 OF 1

This drawing may contain CONFIDENTIAL information and is intended only for the use of the specific individual(s) to which it is addressed.