

8 7 6 5 4 3 2 1

D
C
B
A

D
C
B
A

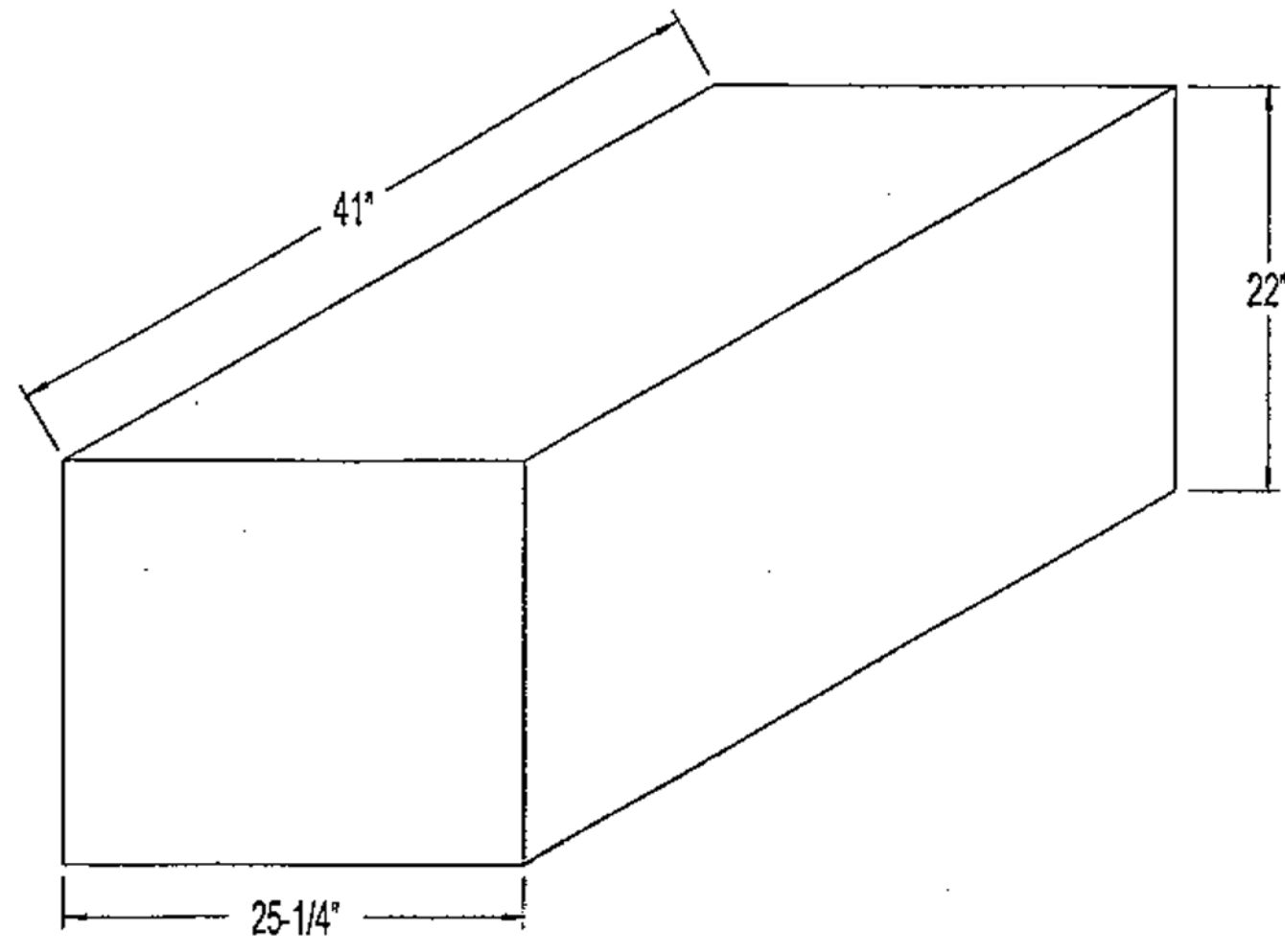

| | | | | | | | |
|-------------|---------|--------------------------------------|-----------|------|------|----------------------|--|
| | | UNLESS OTHERWISE SPECIFIED: | | NAME | DATE | ONE CLARION INC. | |
| | | DIMENSIONS ARE IN INCHES | DRAWN | | | TITLE: | |
| | | TOLERANCES: | CHECKED | | | 95 GALLON WATER TANK | |
| | | FRACTIONAL ± | ENG APPR. | | | SIZE | |
| | | ANGULAR: MACH ± BEND ± | MFG APPR. | | | DWG. NO. | |
| | | TWO PLACE DECIMAL ± | Q.A. | | | REV | |
| | | THREE PLACE DECIMAL ± | COMMENTS: | | | W-218 | |
| | | INTERPRET GEOMETRIC TOLERANCING PER: | | | | WEIGHT: | |
| | | MATERIAL | | | | SHEET 1 OF 1 | |
| | | FINISH | | | | | |
| NEXT ASSY | USED ON | DO NOT SCALE DRAWING | | | | | |
| APPLICATION | | | | | | | |

8 7 6 5 4 3 2 1