

8 7 6 5 4 3 2 1

D
C
B
A

D
C
B
A

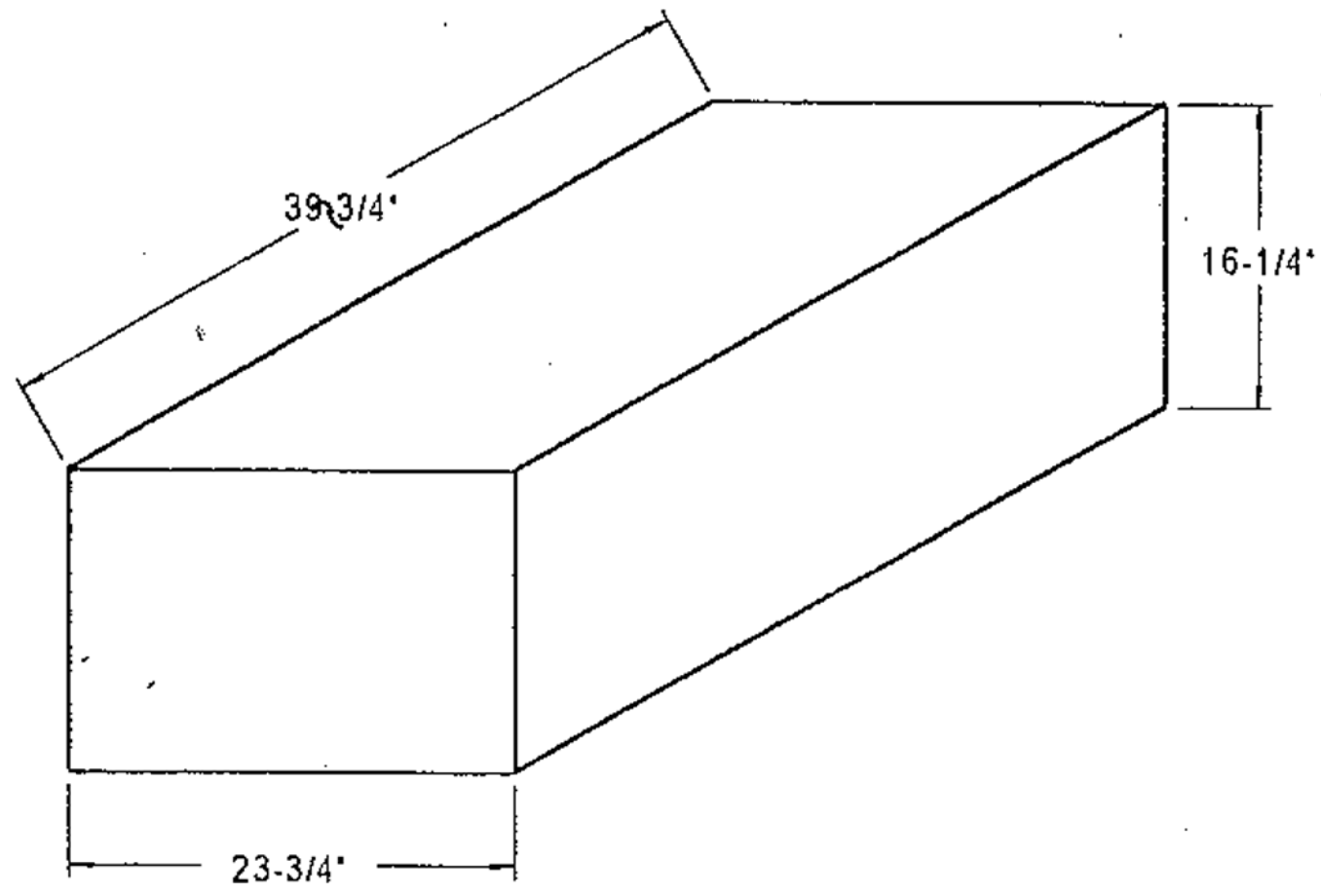

		UNLESS OTHERWISE SPECIFIED:		NAME	DATE	ONE CLARION INC.	
		DIMENSIONS ARE IN INCHES	DRAWN			TITLE:	
		TOLERANCES:	CHECKED			65 GALLON WATER TANK	
		FRACTIONAL ±	ENG APPR.			SIZE	
		ANGULAR: MACH ± BEND ±	MFG APPR.			DWG. NO.	
		TWO PLACE DECIMAL ±	Q.A.			REV	
		THREE PLACE DECIMAL ±	COMMENTS:			W-362	
		INTERPRET GEOMETRIC TOLERANCING PER:				WEIGHT:	
		MATERIAL				SHEET 1 OF 1	
		FINISH					
NEXT ASSY	USED ON	DO NOT SCALE DRAWING					
APPLICATION							

8 7 6 5 4 3 2 1